

BARONNESS
Quality on Demand

LM180C

Super Mower

Owner's operating manual

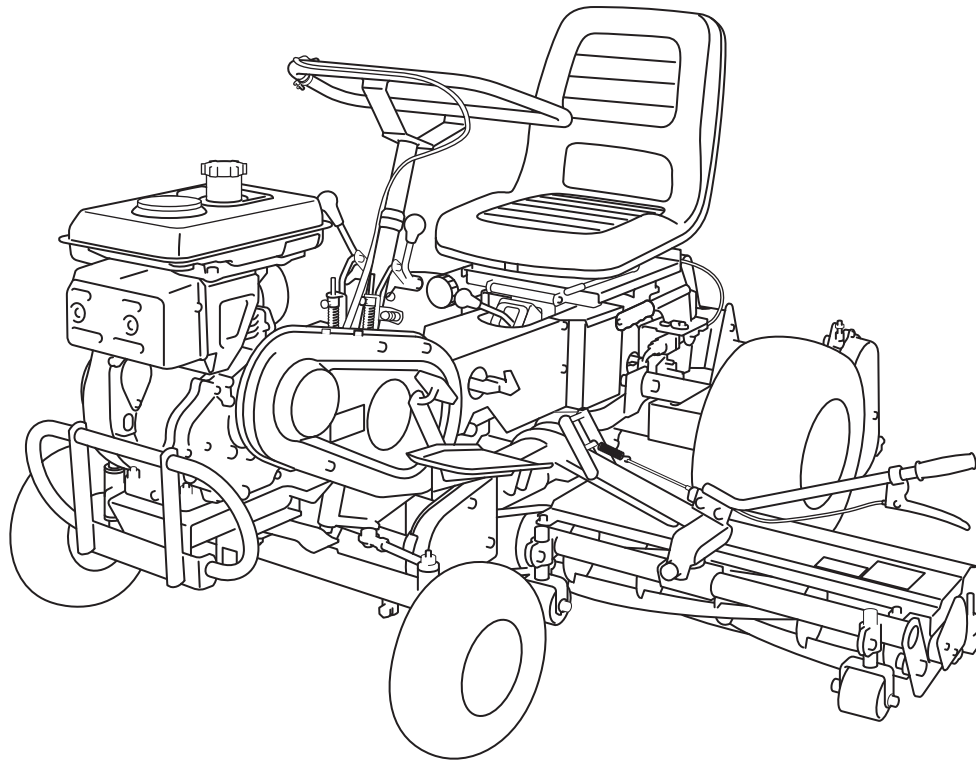

"Required reading" Read this manual and the owner's manual for the engine before using the machine.

Greeting

Thank you for purchasing the Baroness machine. This manual explains proper handling, adjustment, and inspection of your machine.

Prior to use, carefully read this manual to thoroughly understand the contents for safe and correct operation.

We hope you will use the machine safely, and take advantage of its best performance.

Keeping the Owner's Operating Manual

Keep this Owner's Operating Manual in the box on the right side of the seat.

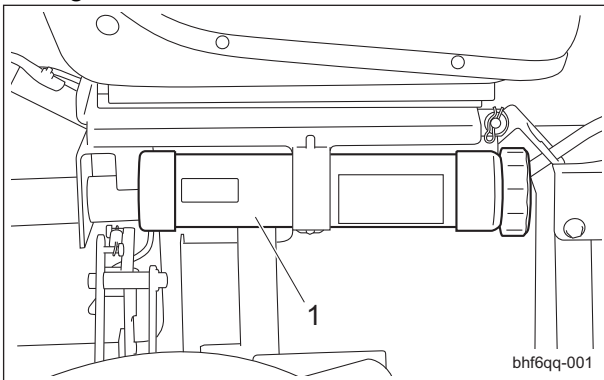

Keeping the Owner's Operating Manual_001

1	Box
---	-----

Read this manual carefully to ensure that you thoroughly understand how to properly operate and maintain this machine, and to avoid causing injury to yourself or others.

The operator is responsible for operating the machine properly and safely.

Do not perform maintenance on the machine other than that described in this manual.

Be sure to also read the operating manuals for the engine, battery, etc.

Maintenance should only be performed by a certified specialist.

If you have any questions concerning maintenance or genuine parts, please contact Kyoisha or your local Baroness dealer.

When making inquiries about this machine, please specify the machine's model designation and serial number.

When loaning or transferring this machine, please also provide the Owner's Operating Manual together with the machine.

Kyoisha Co., Ltd.

Caution

The information described in this manual is subject to change for improvement without prior notice.

When replacing parts, be sure to use genuine Baroness parts or parts designated by Kyoisha.

Note that the Baroness product warranty may not apply to defects caused by the use of parts from other companies.

Warning Symbols

This manual uses the following warning symbols for handling precautions that are important for your safety.



696cq5-001

Warning symbol

This symbol is accompanied by the word “Danger,” “Warning,” or “Caution.”

All labels with this symbol describe important safety precautions, so please read such labels carefully and only operate the machine after you have understood them completely.

Failure to adequately follow these safety precautions may cause an accident.

Danger

This symbol indicates that serious injury or death will occur if the warning is ignored.

Warning

This symbol indicates that serious injury or death may occur if the warning is ignored.

Caution

This symbol indicates that injury or damage to property may occur if the warning is ignored.

Important

This symbol indicates precautions on the mechanism of the machine.

Introduction

Purpose

This machine is intended for cutting turf grass at golf courses.

Do not use this machine in any way other than its intended purpose, and do not modify the machine.

Operating this machine for other purposes and modifying it may be very dangerous and may cause damage to the machine.

In addition, this machine is not authorized for operation as a special motor vehicle. Do not operate it on public roads.

Safety	Page 1-1
Safe Operating Practices.....	Page 1-2
Disposal	Page 2-1
Waste disposal.....	Page 2-2
Product Overview	Page 3-1
Specifications.....	Page 3-2
Names of Each Section.....	Page 3-3
Safety Signs and Instruction Signs.....	Page 3-4
Handling Instructions	Page 4-1
Inspection Before Use.....	Page 4-2
Tightening torques.....	Page 4-7
Adjustment Before Operating.....	Page 4-9
Procedure to Start / Stop Engine.....	Page 4-10
Operation of Each Section.....	Page 4-11
Travel of Machine.....	Page 4-14
Cutting Work.....	Page 4-14
Transporting.....	Page 4-14
Maintenance	Page 5-1
Maintenance Precautions.....	Page 5-2
Maintenance Schedule.....	Page 5-2
Jacking up the machine.....	Page 5-4
Greasing.....	Page 5-6
Maintenance (Mower).....	Page 5-8
Maintenance (Main Body).....	Page 5-9
Long-Term Storage.....	Page 5-15

Safe Operating Practices..... Page 1-2

Training.....Page 1-2

Preparation..... Page 1-2

Operation..... Page 1-3

Maintenance and storage..... Page 1-4

Safety

Failure to adequately follow these safety precautions may cause an accident resulting in injury or death.

Danger

This machine is designed to ensure safe operation and has been tested and inspected thoroughly before shipment from the factory. The machine is equipped with safety devices to prevent accidents.

However, whether the machine demonstrates its original performance level depends on the manner in which it is operated and handled, as well as the manner in which it is managed on a daily basis.

Inappropriate use or management of the machine may result in injury or death.

Observe the following safety instructions to ensure safe operation.

Safe Operating Practices

The following instructions include the ones from CEN standard EN 836: 1997, ISO standard 5395: 1990, and ANSI B71.4-2004.

Training

1. Read the Owner's operating Manual and other training material carefully. Be familiar with the controls, safety signs, and the proper use of the equipment.
2. If the operator or mechanic can not read English it is the owner's responsibility to explain this material to them.
3. All operators and mechanics should seek and obtain professional and practical instruction. The owner is responsible for training the users. Such instruction should emphasize.
 - [1] The need for care and concentration when working with ride-on machines.
 - [2] Control of a ride-on machine sliding on a slope will not be regained by the application of the brake. The main reasons for loss of control are
 - Insufficient wheel grip
 - Being driven too fast
 - Inadequate braking
 - The type of machine is unsuitable for its task

- Lack of awareness of the effect of ground conditions, especially slopes
- Incorrect hitching and load distribution

4. Never allow untrained personnel to service machine. Local regulations may restrict the age of the operator.
5. The owner/user can prevent and is responsible for accidents or injuries occurring to themselves, other people, or property.
6. Keep in mind that the owner, operator, and mechanic are responsible for accidents or hazards occurring to other people or their property.

Preparation

1. Evaluate the terrain to determine what accessories and attachments are needed to properly and safely perform the job. Only use accessories and attachments approved by the manufacturer.
2. While operating, always wear substantial footwear, long trousers, hard hat, safety glasses, and ear protection. Long hair, loose clothing, or jewelry may get tangled in moving parts. Do not operate the equipment when barefoot or wearing open sandals.
3. Inspect the area where the equipment is to be used and remove all objects such as rocks, toys and wire which can be thrown by the machine.
4. Exercise care in the handling of fuel.

Warning

Warning-Fuel is highly flammable. Take the following precautions.

- [1] Store fuel in containers specifically designed for this purpose.
- [2] Add fuel before starting the engine. Never remove the cap of the fuel tank or add fuel while the engine is running or when the engine is hot.
- [3] Refuel outdoors only and do not smoke while refueling.
- [4] If fuel is spilled, do not attempt to start the engine but move the machine away from the area of spillage and avoid creating any source of ignition until petrol vapours have dissipated.

- [5] Replace all fuel tanks and container caps securely.
5. Check that operator's presence controls, safety switches and shields are attached and functioning properly. Do not operate unless they are functioning properly.
6. If the brake operation is faulty or the parking brake lever has noticeable play, be sure to adjust or repair them before operating the machine.
7. Replace faulty mufflers.
6. Do not change the engine governor settings or overspeed the engine. Operating the engine at excessive speed may increase the hazard of personal injury.
7. Do the following before leaving the operator's position.
 - [1] Stop on level ground.
 - [2] Disengage the power take-off and lower the attachments.
 - [3] Change into neutral and set the parking brake.
 - [4] Stop the engine and remove the key.

Operation

1. Do not operate the engine in a confined space where dangerous carbon monoxide fumes can collect.
2. Only operate in good light, keeping away from holes and hidden hazards.
3. Before attempting to start the engine, disengage all attachments, shift into neutral, and engage the parking brake. Only start engine from the operator's position. Use seat belts if provided.
4. Remember there is no such thing as a safe slope. Travel on grass slopes requires particular care. To guard against overturning:
 - [1] Do not stop or start suddenly when going up or downhill.
 - [2] Engage clutch slowly, always keep machine in gear, especially when traveling downhill.
 - [3] Machine speeds should be kept low on slopes and during tight turns.
 - [4] Stay alert for humps and hollows and other hidden hazards.
 - [5] Never operate across the face of the slope, unless the machine is designed for this purpose.
 - [6] Never drive the machine on a slope with an angle of gradient that is greater than that specified or in a place where there is a danger of the machine slipping.
5. Never operate the machine with damaged guards, shields, or without safety protective devices in place. Be sure all interlocks are attached, adjusted and functioning properly.
8. Disengage the drive to attachments, stop the engine, and remove the ignition key in the following conditions.
 - [1] Before refueling.
 - [2] Before removing the grass catcher/catchers.
 - [3] Before making height adjustment unless adjustment can be made from the operator's position.
 - [4] Before cleaning blockages.
 - [5] Before checking, cleaning, or working the machine.
 - [6] After striking a foreign object or if an abnormal vibration occurs. Inspect the machine for damage and make repairs before restarting and operating the equipment.
9. Keep hands and feet away from the cutting units and the rotating parts.
10. Look behind and down before backing up to be sure of a clear path.
11. Do not carry passengers.
12. Never operate while people, especially children, or pets are nearby.
13. Slow down and use caution when making turns and crossing roads and sidewalks.
14. Stop the blades rotating before crossing surfaces other than grass.
15. Disengage drive to attachments when transporting or not in use.
16. When using any attachments, never direct discharge of material toward bystanders nor allow anyone near the machine while in operation.
17. Do not operate the machine under the influence of alcohol or drugs.

Safety

18. Take care when loading or unloading the machine into a trailer or a truck. Load or unload the machine in a flat and safe place. Before loading or unloading, set the parking brake on the truck or trailer, stop the engine, and chock the wheels.
When transporting the machine on a truck or a trailer, set the parking brake, stop the engine, and fasten the machine to the truck with a rope or other suitable restraining device that has sufficient strength.
When using a running board, select one with sufficient strength, length, and width and that will not cause the machine to slip.
19. Close the fuel valve before transporting the machine.
20. Use care when approaching blind corners, shrubs, trees, or other objects that may obscure vision.
21. Do not take your eyes off the road ahead. Do not operate the machine with no hands.
22. Reduce the throttle setting during engine run-out and, if the engine is provided with a shut-off valve, turn the fuel off at the conclusion of operation.
9. Never allow untrained personnel to service machine.
10. Allow the engine/muffler to cool before checking/maintenance.
11. Appropriately manage and correctly use the tools necessary for servicing or adjusting the machine.
12. Use jack stands to support components when required.
13. Carefully release pressure from components with stored energy.
14. Make sure that parts such as wires are not touching each other and that their covers have not come off.
15. Use care when checking the cylinders/reels and bed knives.
 - [1] Wear gloves and use caution when servicing them.
 - [2] Be careful during adjustment of the machine to prevent entrapment of the fingers between moving blades and fixed parts of the machine.
16. On multi-cylinder/multi-reel machines take care as rotating one cylinder/reel can cause other cylinder/reels to rotate.

Maintenance and storage

1. Disengage drives on level ground, lower the attachments, set parking brake, stop engine and disconnect spark plug wire. Wait for all movement to stop before adjusting, cleaning or repairing.
2. When machine is to be parked, stored, or left unattended, lower the cutting units unless a positive mechanical lock is provided.
3. To reduce the fire hazard, keep the engine, silencer/muffler, battery compartment fuel storage area, cutting unit and drives free of grass, leaves, or excessive grease. Clean up oil or fuel spillage.
4. Allow the engine to cool before storing in any enclosure.
5. Only cover the machine with a sheet after hot parts have sufficiently cooled down.
6. Never store the equipment with fuel in the tank inside a building where fumes may reach an open flame or spark.
7. Do not store fuel near flames.
8. If the engine is provided with a shut-off valve, shut off valve while storing or transporting.
17. Keep hands and feet away from moving parts. If possible, do not make adjustments with the engine running.
18. Keep all parts in good working condition and all hardware tightened. Replace all worn or damaged decals.
19. Keep all nuts, bolts and screws tight to be sure the equipment is in safe working condition.
20. Check the grass catcher frequently for wear or deterioration.
21. If the fuel tank has to be drained, do this outdoors.

Waste disposal.....Page 2-2

About the Waste disposal.....Page 2-2

Disposal

Waste disposal

About the Waste disposal

Make sure that waste generated when servicing or repairing the machine is disposed of in accordance with local regulations.

(e.g. waste oil, antifreeze batteries, rubber products, and wires etc.)

Specifications..... Page 3-2

- Specifications.....Page 3-2
- Sound pressure level..... Page 3-2
- Sound power level..... Page 3-2
- Vibration level..... Page 3-3

Names of Each Section..... Page 3-3

- Serial Number Plate.....Page 3-3
- Specification Decal..... Page 3-3
- Noise Emission Decal.....Page 3-4
- Year of Manufacture Decal..... Page 3-4

Safety Signs and Instruction Signs..... Page 3-4

- About Safety Signs and Instruction Signs.....Page 3-4
- Positions of Safety Decals and Instruction Decals..... Page 3-4
- Explanation about Safety Decals and Instruction Decals..... Page 3-5

Product Overview

Specifications

Specifications

Type		LM180C	
Dimensions	Total length	215 cm	
	Total width	During operation	208 cm
		During transport	185 cm
	Total height	Seat	107 cm
Steering wheel		102 cm	
Weight		387 kg	
Minimum turning radius		230 cm	
Engine	Type	Subaru EH30B	
	Type	Air-cooled 4-cycle vertical OHV-type gasoline engine	
	Total displacement	291 cm ³ (0.291 L)	
	Maximum output	6.6 kW (9.0PS)/1,800 rpm	
Fuel tank capacity		Gasoline 6.0 dm ³ (6.0 L)	
Fuel consumption		310 g/kW.h (at continuous rated output)	
Quantity of engine oil		1.2 dm ³ (1.2 L)	
Operating width (Mowing width)		188 cm	
Mowing height		13 - 50 mm	
Drive		Mechanical two-wheel drive	
Speed (HST)		-	
Speed (Mechanical)	Forward	1st gear: 3.1 km/h 2nd gear: 6.4 km/h 3rd gear: 9.4 km/h	
	Reverse	1st gear: 3.1 km/1,800 rpm	
Efficiency		9,630 m ² /h (6.4 km/h x mowing width x 0.8)	
Maximum inclination for operation		18 degrees	
Tire size	Front wheel	4.00 - 5	
	Rear wheel	18 × 8.50 - 8	
Tire Pneumatic Pressure	Front wheel	200 kPa (2.0 kgf/cm ²)	
	Rear wheel	80 kPa (0.8 kgf/cm ²)	
Battery		-	

* The factory default maximum engine rpm is 1,800 rpm.

Sound pressure level

Sound pressure

This machine was confirmed to have a continuous A-weighted sound pressure level of 93 dB by measuring identical machines in accordance with the procedure specified in CEN EN836:1997.

Sound power level

Sound power

This machine was confirmed to have a sound power level of 105 dB by measuring identical machines in accordance with the procedure specified in directive 2000/14/EC.

Vibration level

Hand-arm vibration

This machine was confirmed to transmit a maximum vibration level of 3.63 m/s² to hands and arms by measuring identical machines in accordance with the procedure specified in ISO 5349-1:2001-5349-2:2001.

Whole body vibration

This machine was confirmed to transmit a maximum vibration level of 1.12 m/s² to the whole body by measuring identical machines in accordance with the procedure specified in ISO 2631-1:1997-2631:2003.

1	Steering wheel
2	Traveling clutch lever
3	Change lever
4	Parking brake lever
5	Left mower unit
6	Diff-lock pedal
7	Reel rotation lever
8	Engine stop switch
9	Throttle lever
10	Box
11	Brake pedal
12	Right mower unit
13	Rear mower unit
14	Seat
A	Serial number plate
B	Specification Decal
C	Noise Emission Decal
D	Year of Manufacture Decal

Names of Each Section

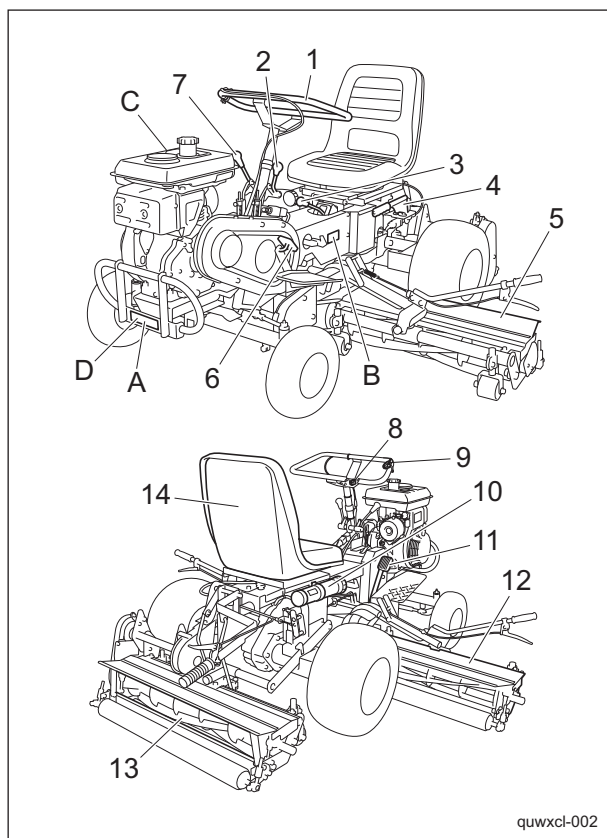

Names of Each Section_001

Serial Number Plate

The serial number plate indicates the name and serial number of the machine.

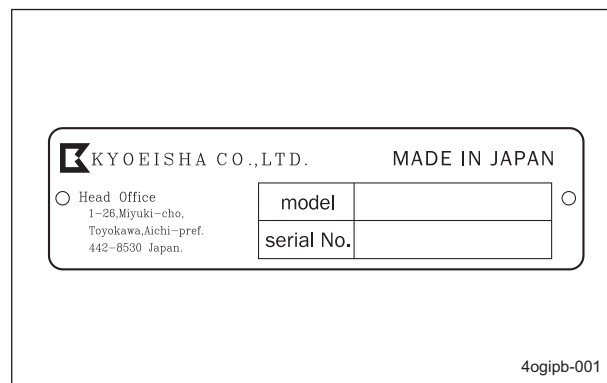

Serial Number Plate_001

Specification Decal

The Specification decal indicates the CE logo, model name, and weight, etc.

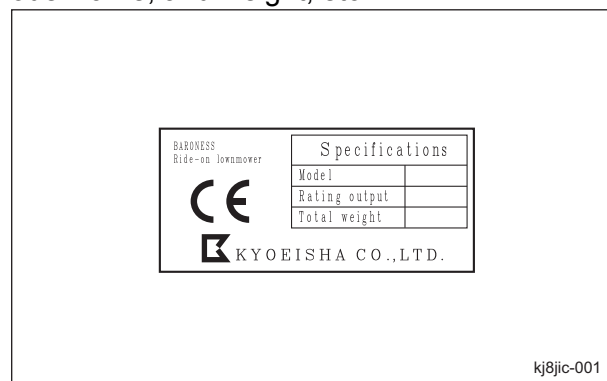

Decal, Specifications_001

Product Overview

Noise Emission Decal

The noise emission decal indicates the sound power level determined by measuring identical machines in accordance with the procedure specified in the EC directives.

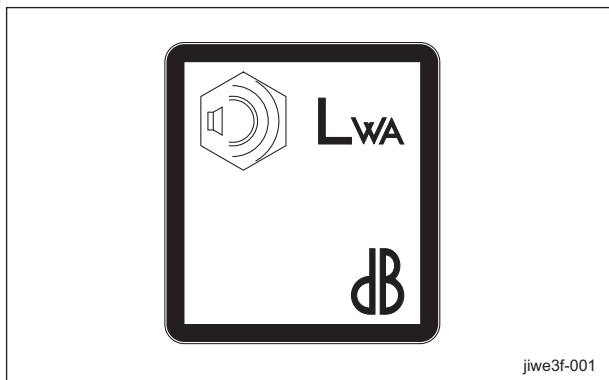

Noise Emission Decal_001

Year of Manufacture Decal

The year of manufacture decal indicates the year when this machine was manufactured.

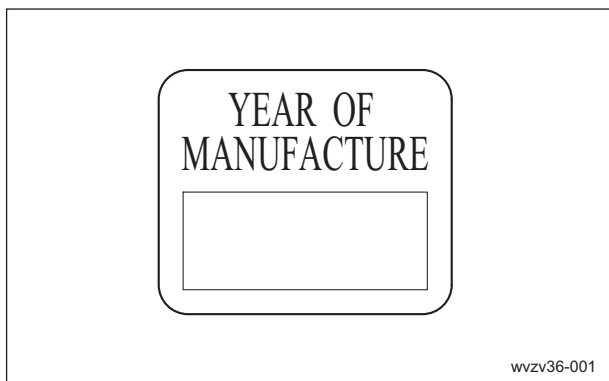

Year of Manufacture Decal_001

Safety Signs and Instruction Signs

About Safety Signs and Instruction Signs

Warning

Safety decals and instruction decals are attached to this machine. Make sure that they are preserved in their entirety. If they are damaged, become dirty, or peel off, replace them with new ones.

Part numbers for decals that need to be replaced are listed in the parts catalog. Order them from a Baroness dealer or Kyoisha.

Positions of Safety Decals and Instruction Decals

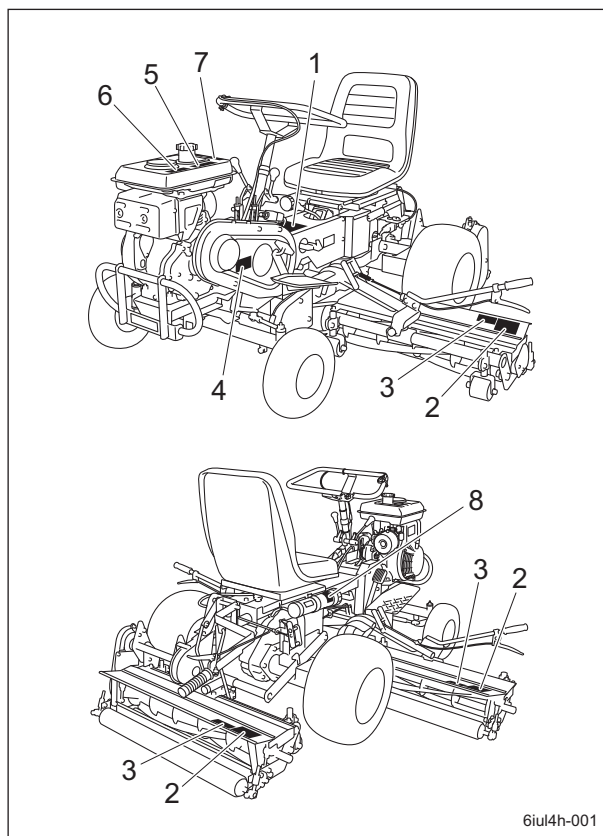

Positions of Safety Decals and Instruction Decals_001

Explanation about Safety Decals and Instruction Decals

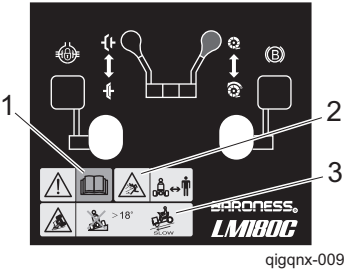
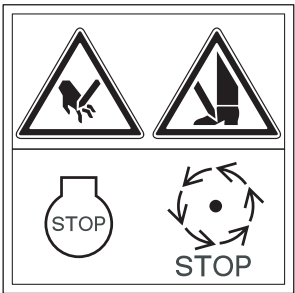
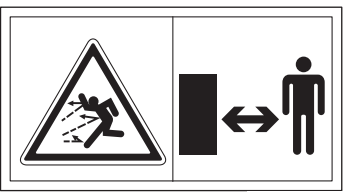
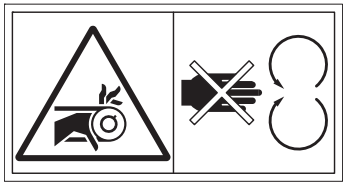
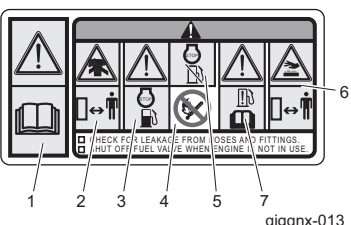
<p>1</p>	 <p>qigqnx-009</p>	<p>LM180C-1001Z0 Sticker, operation</p> <ol style="list-style-type: none"> Warning Read the manual. Danger Flying objects - All persons other than the operator must keep a safe distance from the machine. Danger Rollover - Do not work on slopes of 18 degrees or more. When you descend a slope, lower the mower units and drive at low speed.
<p>2</p>	 <p>qigqnx-010</p>	<p>K4205001600 Decal, caution to mutilation</p> <p>Danger</p> <p>May cut your hand or leg - Stop the rotation and engine. Otherwise you may get injured.</p>
<p>3</p>	 <p>qigqnx-011</p>	<p>K4205001650 Decal, caution to flying object</p> <p>Danger</p> <p>Caution to flying object - When the blades are rotating, keep away from the machine. All bystanders must keep a safe distance from the machine.</p>
<p>4</p>	 <p>qigqnx-012</p>	<p>K4205001530 Decal, caution to rotating object</p> <p>Danger</p> <p>Watch for rotating parts - Keep your hands away from the belts while the engine is running.</p>
<p>5</p>	 <p>qigqnx-013</p>	<p>R073-20057-60 Decal, engine alert</p> <ol style="list-style-type: none"> Read the manual. Exhaust gas is poisonous. Do not operate in an unventilated room or enclosed area. Stop the engine before refueling. Fire, open flame and smoking are prohibited. Shut off fuel valve when the engine is not in use.

Product Overview

<p>5</p>	<p>qigqnx-013</p>	<p>6. Stay clear of the hot surface. 7. Check for leakage from hose and fittings.</p>
<p>6</p>	<p>qigqnx-014</p>	<p>R073-20046-40 Decal, engine alert Spark plug cover must be in place when refueling.</p>
<p>7</p>	<p>qigqnx-015</p>	<p>K4205001330 Decal, caution to noise</p>
<p>8</p>	<p>qigqnx-017</p>	<p>K4205001560 Decal, read Owner's manual Warning Read the manual.</p>

Handling Instructions

Inspection Before Use.....	Page 4-2	Cutting Work.....	Page 4-14
Reel Cutter (Cutting Cylinder) and Bed Knife (Bottom Blade).....	Page 4-2	Cutting Operation.....	Page 4-14
Air cleaner.....	Page 4-2	Transporting.....	Page 4-14
Tire.....	Page 4-3	Transporting Procedure.....	Page 4-14
Brake.....	Page 4-3		
Belt.....	Page 4-3		
Engine.....	Page 4-3		
Engine Oil.....	Page 4-3		
Transmission.....	Page 4-5		
Fuel.....	Page 4-6		
Oil Leakage.....	Page 4-6		
Tightening torques.....	Page 4-7		
Standard tightening torques.....	Page 4-7		
Principal tightening torques	Page 4-8		
Adjustment Before Operating.....	Page 4-9		
Adjustment of Seat.....	Page 4-9		
Adjustment of Blade Engagement.....	Page 4-9		
Adjustment of Cutting Height.....	Page 4-10		
Procedure to Start / Stop Engine.....	Page 4-10		
Start / Stop of Engine.....	Page 4-10		
Operation of Each Section.....	Page 4-11		
Precautions for Operating the Machine.....	Page 4-11		
Cautions for when You Leave the Machine.....	Page 4-11		
Instruction Decals.....	Page 4-11		
Throttle Lever.....	Page 4-11		
Lifting lever.....	Page 4-11		
Operation of Change Lever.....	Page 4-12		
Traveling Clutch Lever.....	Page 4-13		
Operation of Reel Rotation Lever.....	Page 4-13		
Operation of Brake Pedal.....	Page 4-13		
Operation of Diff-lock Pedal.....	Page 4-13		
Parking Brake Lever.....	Page 4-13		
Travel of Machine.....	Page 4-14		
Moving the Machine.....	Page 4-14		

Handling Instructions

Inspection Before Use

Be sure to perform an inspection before you start using the machine so that you will be able to take advantage of its optimum performance for a long period of time.

Reel Cutter (Cutting Cylinder) and Bed Knife (Bottom Blade)

Inspection of Reel Cutter (Cutting Cylinder) and Bed Knife (Bottom Blade)

The reel cutter (cutting cylinder) and bed knife (bottom blade) may become dull due to frequent use, objects crushed during mowing, or damage caused during transportation. Inspect the reel cutter (cutting cylinder) and bed knife (bottom blade), and if necessary, adjust the blade engagement and perform lapping, resharpen, or replace the reel cutter (cutting cylinder) and the bed knife (bottom blade).

1. Check to see whether or not the edge of the reel cutter (cutting cylinder) and the bed knife (bottom blade) are too blunt to cut.
2. Make sure that the reel cutter (cutting cylinder) and the bed knife (bottom blade) are not cracked.
3. Check to see how much the reel cutter (cutting cylinder) and the bed knife (bottom blade) are worn.
4. Make sure that the reel cutter (cutting cylinder) and the bed knife (bottom blade) have not changed color due to heat from grinding.
5. Check to see whether or not the second edge face remains at the point of reel cutter (cutting cylinder).
6. Make sure that the welding between the reel cutter (cutting cylinder) and the disc has not come off.

Air cleaner

Inspection of Air Cleaner

For details on handling the engine, please refer to the separate Engine Handling Manual. The air cleaner is a component that removes dirt from the intake air to prevent wear of the cylinder liners and piston rings so that the engine will always operate smoothly. A contaminated air cleaner element may cause malfunction of the engine.

1. Make sure that there is no damage to the air cleaner.
2. Make sure that the air cleaner is not contaminated.

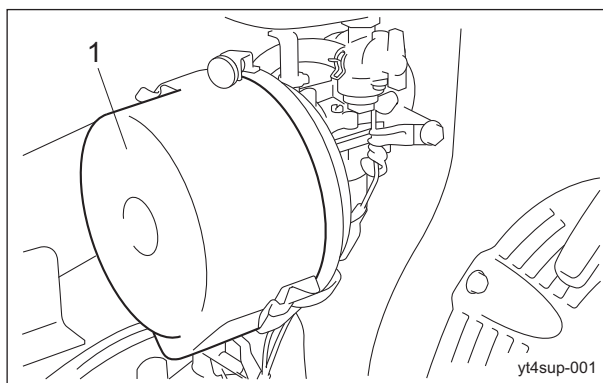

Inspection of Air Cleaner_001

1	Air cleaner
---	-------------

Cleaning of Air Cleaner

For details on handling the engine, please refer to the separate Engine Handling Manual. A contaminated air cleaner element may cause malfunction of the engine.

To maximize the life of the engine, clean the air cleaner properly.

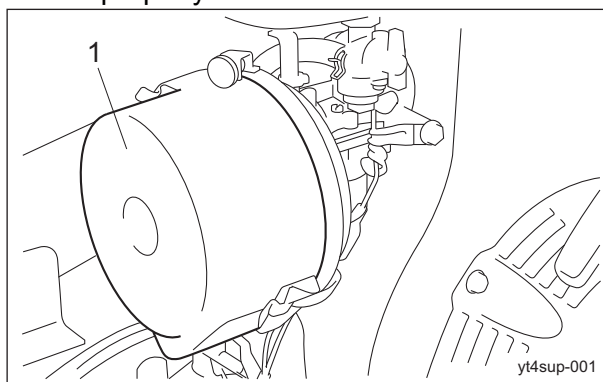

Cleaning of Air Cleaner_001

1	Air cleaner
---	-------------

Handling Instructions

1. Follow the steps below to clean the air cleaner.

- [1] Before installing the element, clean it with white kerosene, immerse it in an admixture of three parts white kerosene to one part engine oil, and then shake/squeeze it.
- [2] Before installing the urethane foam, clean it with white kerosene, immerse it in an admixture of three parts white kerosene to one part engine oil, and then firmly squeeze it.

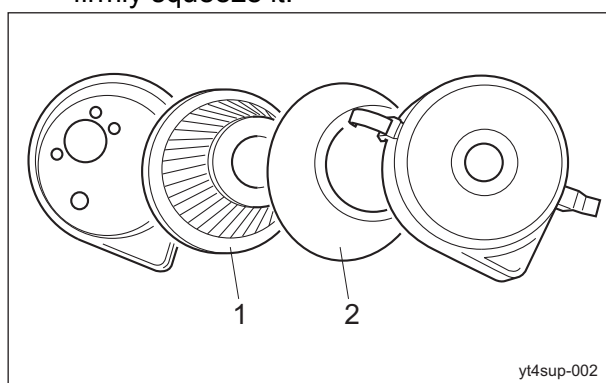

Cleaning of Air Cleaner_002

1	Element
2	Urethane foam

Tire

Inspection of Tires

1. Check the pneumatic pressure of the tires.
2. Make sure that there are no cracks, damage or abnormal wear on the tires.

Tire size	Pneumatic pressure
Front wheel (4.00 - 5)	200 kPa (2.0 kgf/cm ²)
Rear wheel 8.50 - 8	80 kPa (0.8 kgf/cm ²)

Brake

Inspection of Parking Brake

1. Make sure that the brake is not applied any longer when you pull the parking brake lever.
2. Make sure that the brake is not applied even slightly when you press the push button to release the parking brake lever.

Inspection of Brake

While traveling, depress the brake pedal until the pedal hits the pedal stopper to make sure that the brake is applied effectively.

Belt

Inspection of Belts

Caution

If you have removed the shield during inspection, make sure that you re-attach it in the original position securely. If the shield remains removed, the operator may come in contact with the fan or belt, possibly resulting in injuries.

Important

A slacking or damaged belt may cause the cutter rotation speed or operation speed to be insufficient for operation.

1. Press the middle of the belt with your finger to check the belt tension.
2. Make sure that there are no cracks, damage or abnormal wear.

Engine

Inspection of Engine

For details on handling the engine, please refer to the separate Engine Handling Manual.

1. Check the fuel system parts for loosened or cracked joints and leakage. Replace the parts if necessary.
2. Blow the air to clean any grass or flammables attached inside or around the muffler.
3. Blow air to clean any grass or flammables attached around the cooling fins or recoil starter.

Engine Oil

Inspection of Engine Oil

1. Stop the engine, wait for 10 to 20 minutes for the engine to cool down, then check the oil level.
2. Position the machine so that the engine oil surface will become level, then insert the oil gauge all the way to check the oil level.

Handling Instructions

3. The appropriate oil level should be between the two knurl lines on the gauge.

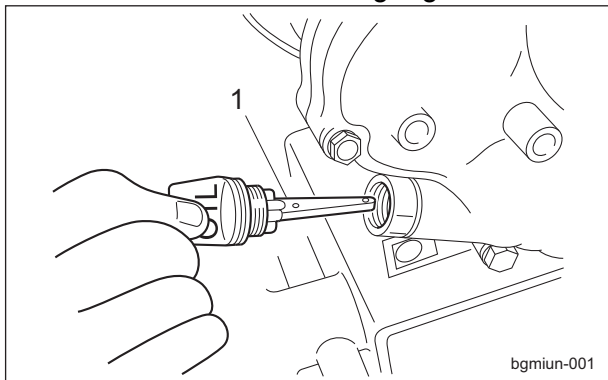

Inspection of Engine Oil_001

1	Oil gauge
---	-----------

Filling of Engine Oil

For details on handling the engine, please refer to the separate Engine Handling Manual.

⚠ Caution

Do not fill too much engine oil. Otherwise, the engine may be damaged.

Important

Do not mix different types of engine oil.

Important

Be sure to use engine oil that is classified as API Service Grade SF or higher, with an SAE Viscosity that is appropriate for the operating environment (ambient temperature).

1. Through the oil filling port, fill the engine oil.
2. Check the oil level again 10 to 20 minutes after supplying the oil.

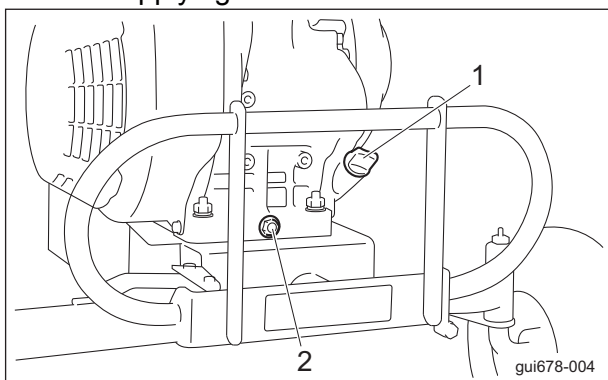

Filling of Engine Oil_001

1	Oil filling port
2	Drain plug

Change of Engine Oil

For details on handling the engine, please refer to the separate Engine Operating Manual.

⚠ Warning

When you change the engine oil, be sure to drain it into a bowl and discard it in accordance with regional laws and regulations.

⚠ Caution

Pay attention to hot oil, which could burn your skin if it gets on you.

Important

Be sure to use engine oil that is classified as API Service Grade SF or higher, with an SAE Viscosity that is appropriate for the operating environment (ambient temperature).

Change the engine oil more frequently, if the engine oil is contaminated, and also in case you use the machine in dusty areas or operate the engine at high loads or in high temperatures.

1. Move the machine onto a level surface, stop the engine, remove the drain plug while the engine oil is warm, then drain the oil into a bowl.
2. Attach the drain plug, then remove the oil gauge.
3. Pour new engine oil through the oil filling port.
Engine oil quantity is approximately 1.2 dm³(1.2 L).
4. Insert the oil gauge straight into the oil filling port all the way, without twisting or turning it, to check the oil level.
Make sure that the engine oil is filled up to the upper limit of the oil gauge.

Handling Instructions

5. Install the oil gauge.

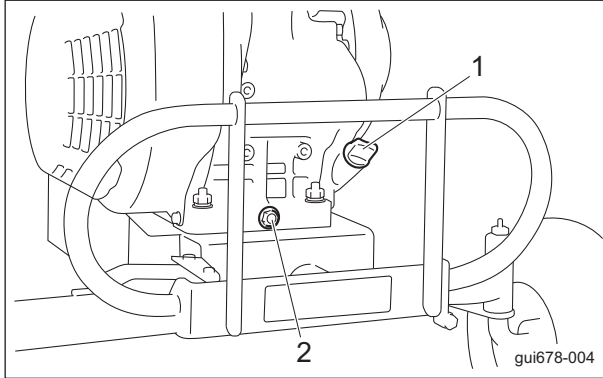

Change of Engine Oil_001

1	Oil filling port / oil gauge
2	Drain plug

Transmission

Inspection of Transmission Oil

Place the machine so that its frame will be level, and then make sure that the transmission oil level is at the oil level plug at any time. The oil level plug is located on the right side of the transmission.

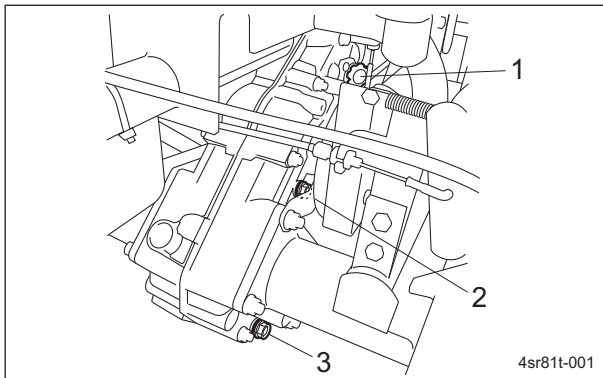

Inspection of Transmission Oil_001

1	Oil filling port
2	Oil level plug
3	Drain plug

Filling of Transmission Oil

Important

Do not mix different types of transmission oil.

Important

Be sure to pour automobile gear oil that is classified as SAE Viscosity Grade #90 into the transmission.

1. Through the oil filling port, fill the transmission oil.
2. Check the oil level again 10 to 20 minutes after filling the oil.

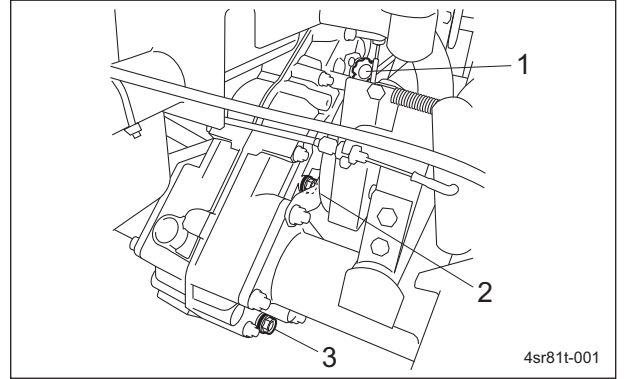

Filling of Transmission Oil_001

1	Oil filling port
2	Oil level plug
3	Drain plug

Change of Transmission Oil

Warning

When you change the transmission oil, be sure to drain it into a bowl and discard it in accordance with regional laws and regulations.

Caution

Be careful with hot oil, which could cause burns if it contacts your skin.

Important

Be sure to pour automobile gear oil that is classified as SAE Viscosity Grade #90 into the transmission.

Change the entire transmission oil after 50 hours of operation for the first time, and then change it every year of operation.

1. Move the machine onto a level surface, stop the engine, remove the drain plug while the transmission oil is warm, then drain the oil into a bowl.
2. Attach the drain plug, then remove the oil filling port cap and oil level plug.
3. Pour new transmission oil through the oil filling port.

The transmission oil quantity is 2.0 dm³ (2.0 liters).

Handling Instructions

4. Make sure that the transmission oil level is filled up to the tip of the oil level opening.
5. Attach the oil filling port cap and oil level plug.

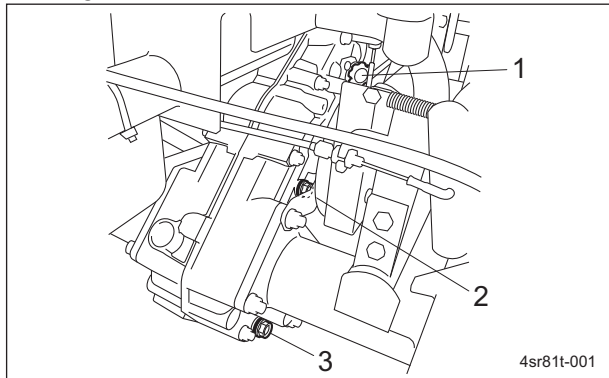

Change of Transmission Oil_001

1	Oil filling port
2	Oil level plug
3	Drain plug

Warning

Keep fire away while refueling.
Do not smoke while refueling.

If the fuel gauge located on the fuel tank indicates a level close to E (EMPTY), supply lead-free gasoline for automobiles at your earliest convenience.

The fuel tank capacity is approximately 6.0 dm³ (6.0 L).

Oil Leakage

Inspection of Oil Leakage

After approximately 50 hours of operation, some joints may be loosened and oil may leak. Check the bottom of the machine for oil leakage.

Fuel

Inspection of Fuel Supply

Observe the fuel gauge located on the fuel tank to check the fuel level.

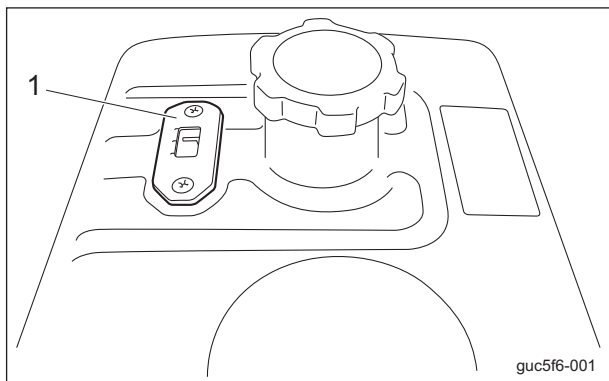

Inspection of Fuel Supply_001

1	Fuel gauge
---	------------

Fuel Supply

Danger

Do not supply fuel above F (FULL) level of the fuel gauge.

If you supply too much fuel, it might overflow from the fuel cap when you travel or work on a slope.

Tightening torques

Standard tightening torques

Bolts and screws

Unless otherwise instructed, tighten bolts or nuts by the specified torque using an appropriate tool. Excessive tightening of a screw may cause it to become loose or damaged. The appropriate tightening torque depends on factors such as the type of screw, its strength, and the friction of its thread and bearing surface.

The following list is for galvanized and parkerized bolts only. The values given in this list do not apply to low-strength female screws.



Do not use a screw that has rusted or has foreign matter such as sand on it. Such a screw cannot be fully tightened even if it is tightened by the specified torque. The friction on the thread surface increases, causing a loss of torque that results in an insufficient tightening torque being exerted. If a screw is wet or oily, do not tighten it by the specified torque. If a screw gets wet, the torque coefficient decreases, resulting in excessive tightening of the screw if it is tightened by the specified torque.

Excessive tightening of a screw may cause it to elongate, resulting in the screw becoming loose or damaged. Do not use a screw that has already been subjected to a large load.

Tightening a bolt with an impact wrench requires skill. Practice tightening bolts to ensure you are able to tighten them reliably.

Nominal diameter	General bolts		
	Strength class: 4.8		
			
	N-m	kgf-cm	lb-in
M5	3 - 5	30.59 - 50.99	26.55 - 44.26
M6	7 - 9	71.38 - 91.77	61.96 - 79.66
M8	14 - 19	142.76 - 193.74	123.91 - 168.17
M10	29 - 38	295.71 - 387.49	256.68 - 336.34
M12	52 - 67	530.24 - 683.20	460.25 - 593.02
M14	70 - 94	713.79 - 958.52	619.57 - 831.99
M16	88 - 112	897.34 - 1142.06	778.89 - 991.31
M18	116 - 144	1,182.85 - 1,468.37	1,026.72 - 1,274.54
M20	147 - 183	1,498.96 - 1,866.05	1,301.10 - 1,619.73
M22	295	3,008.12	2,611.05
M24	370	3,772.89	3,274.87
M27	550	5,608.35	4,868.05
M30	740	7,545.78	6,549.74

Handling Instructions

Nominal diameter	Heat-treated screws					
	Strength category: 8.8			Strength category: 10.9		
	 tib3yb-002			 tib3yb-003		
	N-m	kgf-cm	lb-in	N-m	kgf-cm	lb-in
M5	5 - 7	50.99 - 71.38	44.26 - 61.96	7 - 10	71.38 - 101.97	61.96 - 88.51
M6	8 - 11	81.58 - 112.17	70.81 - 97.36	14 - 18	142.76 - 183.55	123.91 - 159.32
M8	23 - 29	234.53 - 295.71	203.57 - 256.68	28 - 38	285.52 - 387.49	247.83 - 336.34
M10	45 - 57	458.87 - 581.23	398.30 - 504.51	58 - 76	591.43 - 774.97	513.36 - 672.68
M12	67 - 85	683.20 - 866.75	593.02 - 752.34	104 - 134	1,060.49 - 1,366.40	920.50 - 1186.03
M14	106 - 134	1,080.88 - 1,366.40	938.21 - 1,186.03	140 - 188	1,427.58 - 1,917.04	1,239.14 - 1,663.99
M16	152 - 188	1,549.94 - 1,917.04	1,345.35 - 1,663.99	210 - 260	2,141.37 - 2,651.22	1,858.71 - 2,301.26
M18	200 - 240	2,039.40 - 2,447.28	1,770.20 - 2,124.24	280 - 340	2,855.16 - 3,466.98	2,478.28 - 3,009.34
M20	245 - 295	2,498.27 - 3,008.12	2,168.50 - 2,611.05	370 - 450	3,772.89 - 4,588.65	3,274.87 - 3,982.95
M22	-	-	-	530	5,404.41	4,691.03
M24	-	-	-	670	6,831.99	5,930.17
M27	-	-	-	1,000	10,197.00	8,851.00
M30	-	-	-	1,340	14,628.78	11,860.34

Note:

The above values also apply for fine screw threads.

Principal tightening torques

Tightening Torque by Model

LM180C

Tighten the following bolts and nuts at the torque specified in the table.

For thread locking adhesive, apply a mild to high-strength thread locker (ThreeBond 1322 Series Acrylic resin anaerobic adhesives).

Portion		Code	Part name	Tightening Torque			Thread locking adhesive
				N-m	kgf-cm	lb-in	
Front wheel	Front wheel shaft	K0071000082	Bolt, with nipple hole M12-15	36 - 40	371.13 - 407.92	318.64 - 354.04	—
	Wheel mounting shaft	K0000100252	Bolt, M10-25	29 - 38	295.71 - 387.49	256.68 - 336.34	—
	Wheel	K0000080202	Bolt, M8-20	14 - 19	142.76 - 193.74	123.91 - 168.17	—
Rear wheel	Wheel	K0010100252	Bolt, heat-treated M10-25	58 - 76	591.43 - 774.97	513.36 - 672.68	—
Steering		K1604120000	Rod end, spherical bearing LHSA12	52 - 67	530.24 - 683.20	460.25 - 593.02	○
Handle		K0010060202	Bolt, heat-treated M6-20	7 - 9	71.38 - 91.77	61.96 - 79.66	—
Transmission pulley		K0010060151	Bolt, heat-treated M6-15	7 - 9	71.38 - 91.77	61.96 - 79.66	○

Handling Instructions

Portion		Code	Part name	Tightening Torque			Thread locking adhesive
				N-m	kgf-cm	lb-in	
Mower	Bed knife (Bottom blade)	K0071000092	Screw, heat-treated flathead M10-20	29 - 38	295.71 - 387.49	256.68 - 336.34	—
	Front roller	K0010100252	Bolt, heat-treated M10-25	58 - 76	591.43 - 774.97	513.36 - 672.68	—
Engine		K0000100452	Bolt, M10-45	29 - 38	295.71 - 387.49	256.68 - 336.34	○
Seat		K0013101302	Bolt, heat-treated M10-130	29 - 38	295.71 - 387.49	256.68 - 336.34	—

Adjustment Before Operating

Adjustment of Seat

Use the seat adjustment lever to adjust the seat back and forth.

Adjust the position according to the operator's body size.

The adjustment lever is attached to the left of the seat.

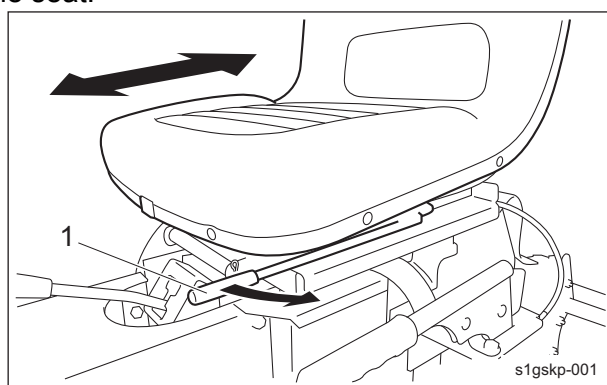

Adjustment of Seat_001

1	Adjustment lever
---	------------------

Adjustment of Blade Engagement

⚠ Caution

Before cutting newspaper as a test, be sure to stop the engine and wear gloves to protect your hands.

Pay attention not to let the reel cutter (cutting cylinder) catch your gloves. Otherwise, you may injure your hand or fingers.

Adjust the engagement between the reel cutter (cutting cylinder) and the bed knife (bottom blade) so that newspaper (two pieces) will be cut by the edge of both blades when the blades in their entirety come slightly into contact with each other via the adjusting nuts.

Insert two or three strips of newspaper into the space between the reel cutter (cutting cylinder) and the bed knife (bottom blade) at an angle of 90 degrees, then rotate the reel cutter (cutting cylinder) from up to down manually to check the sharpness.

Check the sharpness at entire range (three or four points from left edge to right one) of the reel cutter (cutting cylinder).

1. If a gap is created between edges:

[1] Loosen the lock nut and slightly loosen nut B.

[2] Contact the reel cutter (cutting cylinder) and bed knife (bottom blade) slightly, then tighten nut A.

2. If the reel cutter (cutting cylinder) is too tight to turn:

[1] Loosen the lock nut and slightly loosen nut A.

[2] Reduce the contact pressure between the reel cutter (cutting cylinder) and bed knife (bottom blade), then tighten nut B.

Handling Instructions

3. If the blades still cannot cut well:
Perform lapping of the reel cutter (cutting cylinder).

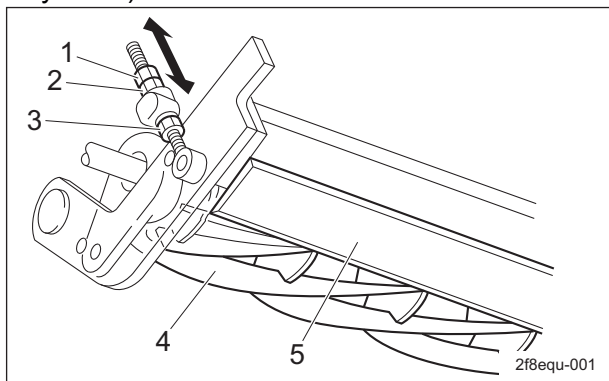

Adjustment of Blade Engagement_001

1	Lock nut
2	Nut A
3	Nut B
4	Reel cutter (Cutting cylinder)
5	Bed knife (Bottom blade)

2. To decrease cutting height:
Loosen nut B, raise the roller, then tighten nut A.

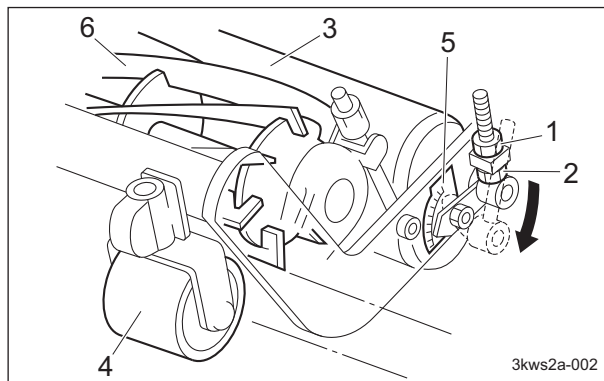

Adjustment of Cutting Height_001

1	Nut A
2	Nut B
3	Roller
4	Front wheel
5	Cutting height scale plate
6	Reel cutter (cutting cylinder)

Adjustment of Cutting Height

Important

The front wheel is provided to prevent the reel cutter (cutting cylinder) from damaging a convex portion of the lawn surface.

Adjust the height so that the front wheel will not be grounded but raised by 10-20mm off the ground.

The cutting height is adjusted by moving the roller up or down.
Refer to the cutting height scale plate to decide the height.

1. To increase cutting height:
Loosen nut A, lower the roller, then tighten nut B.

Procedure to Start / Stop Engine

Start / Stop of Engine

Procedure to Start Engine

Warning

Before starting the engine, make sure that there are no other people or obstacles around the machine.

1. Sit on the seat.
2. Depress the brake pedal, and then pull the parking brake lever.
3. Shift the traveling clutch lever and reel rotation lever to the "OFF" position, and shift the change lever to the neutral position.
4. Open the fuel cock.
The fuel cock is located under the fuel tank.
5. Shift the throttle lever from the "Low" to "High" position.
6. Pull the choke knob.
Pull the knob half way for restarting, as necessary.
7. Turn on the engine switch, then pull the recoil starter knob.
8. Make sure that the engine has started, and then slowly return the choke knob to its original position.

Handling Instructions

9. Shift the throttle lever to "Low", and then warm up the engine for 1 to 2 minutes.
10. Gradually move the throttle lever to "High".

Procedure to Stop Engine

1. Depress the brake pedal, and then pull the parking brake lever.
2. Shift the traveling clutch lever and reel rotation lever to the "OFF" position, and shift the change lever to the neutral position.
3. Move the throttle lever to "Low", and continue idling for 1 to 2 minutes.
4. Turn off the engine switch.
5. Make sure that the engine has stopped.
6. Close the fuel cock.
The fuel cock is located under the fuel tank.
7. Remove the ignition key.
8. Leave the driver's seat.

Operation of Each Section

Precautions for Operating the Machine

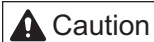

Drive the machine at such a speed that you can stop it immediately for emergencies.

Cautions for when You Leave the Machine

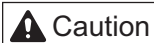

If the brakes are not sufficiently effective, use the wheel stoppers to secure the machine.

Instruction Decals

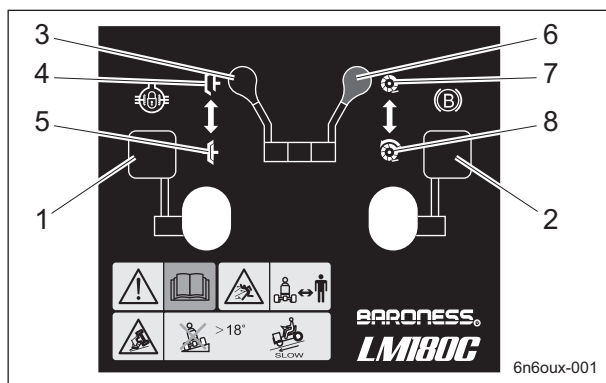

Instruction Decals_001

1	Diff-lock pedal
2	Brake pedal
3	Traveling clutch lever
4	Traveling clutch "OFF"
5	Traveling clutch "ON"
6	Reel rotation lever (Left and right mower units)
7	Reel cutter (cutting cylinder) "STOP"
8	Reel cutter (cutting cylinder) "ROTATE"

Throttle Lever

The throttle lever is located to the right of the steering handle and enables you to adjust the engine rpm.

Move the throttle lever toward "High" to increase the engine rpm, and toward "Low" to reduce the rpm.

Note:

The factory default engine rpm is set to 1,800 rpm.

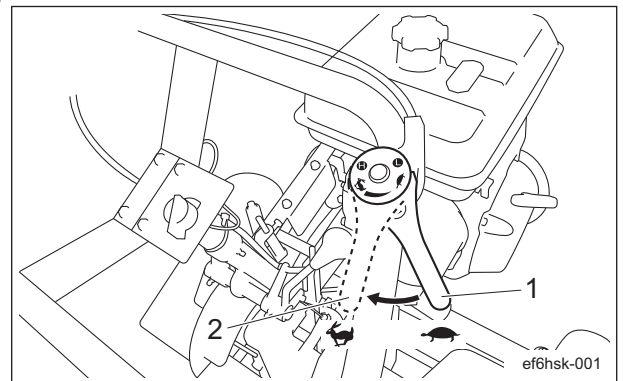

Throttle Lever-001

1	Low (Turtle icon)
2	High (Rabbit icon)

Lifting lever

Left and Right Mower Units

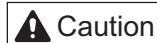

Before raising or lowering the mower units, make sure that there are no people around the machine.

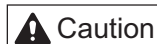

If the reel rotation lever is set to "On," you will be unable to raise the mower units.

Handling Instructions

To lower the left and right mower units, squeeze the clutch lever and slowly move the lifting lever down.

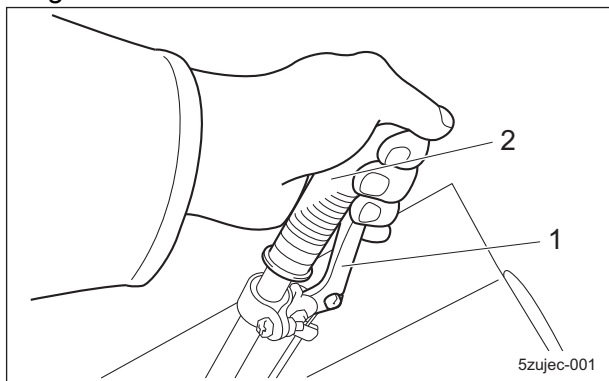

Left and Right Mower Units_001

1	Clutch lever
2	Lifting lever

To lower the rear mower unit, squeeze the clutch lever and slowly move the lifting lever down.

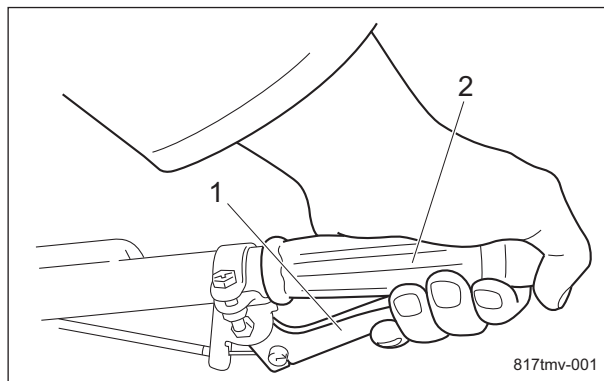

Rear Mower Unit_001

1	Clutch lever
2	Lifting lever

To raise the left and right mower units, raise the lifting lever slowly until the hook metal fitting is secured by the hook.

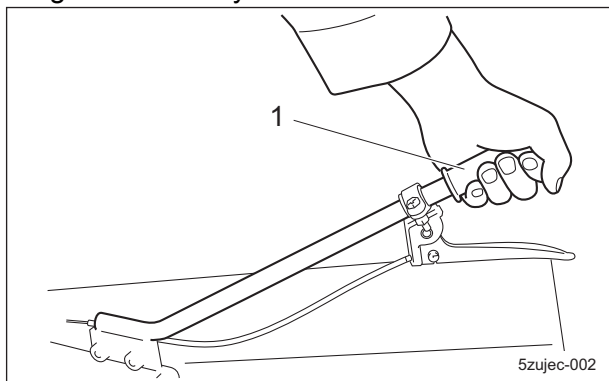

Left and Right Mower Units_002

1	Lifting lever
---	---------------

To raise the rear mower units, raise the lifting lever slowly, and then tilt it fully forward.

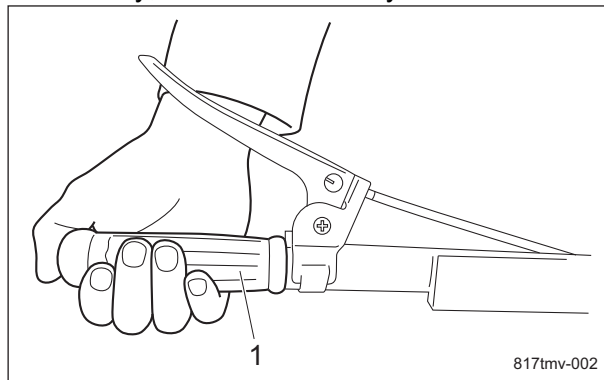

Rear Mower Unit_002

1	Lifting lever
---	---------------

Rear Mower Unit

⚠ Caution

Before raising or lowering the mower units, make sure that there are no people around the machine.

Operation of Change Lever

⚠ Caution

Do not change the lever position during traveling. Otherwise, the transmission may be damaged.

Handling Instructions

The change lever is a transmission device. It was adapted from a direct change system. To change the speed, park the machine on level ground, and then engage the lever in the desired position.

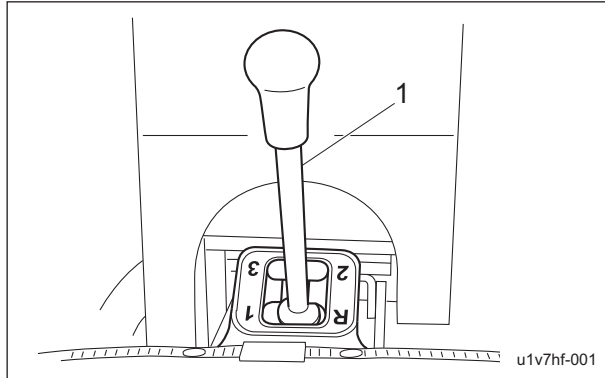

Operation of Change Lever_001

1	Change lever
---	--------------

Traveling Clutch Lever

Caution

Be sure not to engage the throttle lever quickly to the "High" position, in order to avoid sudden acceleration.

To prevent sudden acceleration, pull the traveling clutch lever slowly. Start the machine while allowing the belt to slip in the same way as clutch-slipping. When the traveling clutch is set to the "ON" position, the reel cutter automatically rotates when the rear mower is lowered. When the traveling clutch is set to the "OFF" position, the reel cutter does not rotate, even if the rear mower is lowered.

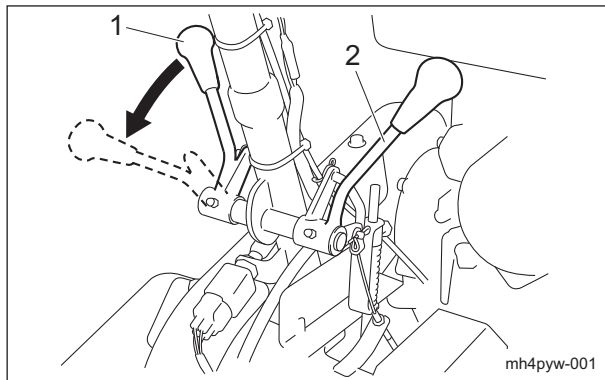

Traveling Clutch Lever_001

1	Traveling clutch lever
2	Reel rotation lever

Operation of Reel Rotation Lever

Caution

Unless both left and right mower units have been lowered all the way, you are not able to operate the reel rotation lever.

To rotate the reel cutter (cutting cylinder) for the left and right mower units, pull the reel rotation lever.

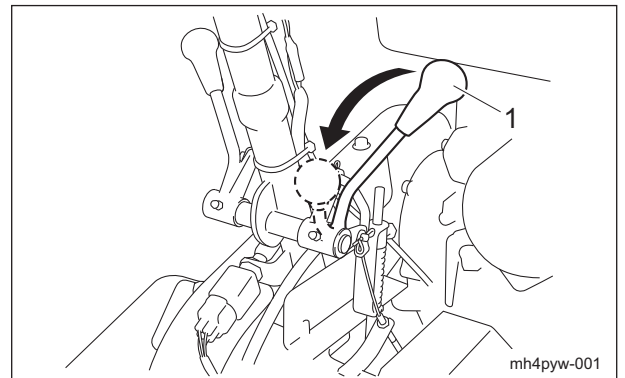

Operation of Reel Rotation Lever_001

1	Reel rotation lever
---	---------------------

Operation of Brake Pedal

The brake pedal is located in the right foot area. In order to stop the machine, depress the brake pedal with your right foot until the pedal hits the pedal stopper.

Operation of Diff-lock Pedal

The diff-lock pedal is located in the left foot area. If you press the diff-lock pedal, the differential device is locked to enhance linearity, thus preventing slipping.

Parking Brake Lever

Caution

Be sure to release the parking brake before driving. It may result in the brakes malfunctioning.

Caution

Never park the machine on a slope.

The parking brake lever is located on the left side of the saddle.

Handling Instructions

To park the machine, pull the parking brake lever completely.

To release the parking brake, press the push button while lowering the parking brake lever all the way to its resting position.

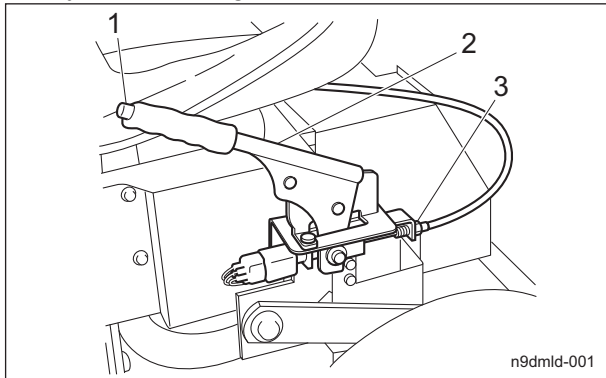

Parking Brake Lever_001

1	Push button
2	Parking brake lever
3	Adjustment bolt

Travel of Machine

Moving the Machine

⚠ Caution

Make sure not to touch rotating tires with your hands or legs.

1. Start the engine. ((See "Procedure to Start Engine" (Page 4-10) .)
2. Depress the brake pedal, and return the parking brake lever to its resting position.
3. Shift the change lever in the appropriate position.
4. Slowly pull the traveling clutch lever in the same way as clutch-slipping.
5. The machine can start traveling.

Cutting Work

Cutting Operation

⚠ Danger

Do NOT start to move or stop the machine abruptly.
To do so is very dangerous. In addition, it may damage the hydraulic system or result in oil leakage.

⚠ Caution

Cutting work must be performed at an appropriate speed for the site and location. When cutting bumpy surfaces, keep the engine rpm steady, and slow down the cutting speed.

1. Start the engine. ((See "Procedure to Start Engine" (Page 4-10) .)
2. Lower the left, right and rear mower units.
3. Depress the brake pedal, and release the parking brake lever.
4. Shift the change lever in the appropriate position.
5. Pull the reel rotation lever to rotate the reel cutters (cutting cylinders) of the left and right mower units.
6. Slowly pull the traveling clutch lever in the same way as clutch-slipping to move the machine forward while rotating the reel cutter (cutting cylinder) of the rear mower unit.
7. Shift the traveling clutch lever to the "ON" position, and then start the operation.

Transporting

Transporting Procedure

When loading the machine into a trailer or a truck to transport it, drive the machine in reverse. When unloading, drive the machine forward.

Maintenance Precautions.....	Page 5-2
Maintenance Schedule.....	Page 5-2
Specified Values.....	Page 5-4
Main Consumable Parts.....	Page 5-4
Jacking up the machine.....	Page 5-4
About the Jacking up the machine.....	Page 5-4
Jack-up Portion.....	Page 5-5
Greasing.....	Page 5-6
About the Lubrication.....	Page 5-6
Greasing Points.....	Page 5-6
Maintenance (Mower).....	Page 5-8
Lapping of Reel Cutter (Cutting Cylinder).....	Page 5-8
Maintenance (Main Body).....	Page 5-9
Removing/Installing Tires.....	Page 5-9
Adjustment of Belt Tension.....	Page 5-10
Adjustment of Parking Brake.....	Page 5-12
Adjustment of Brake.....	Page 5-13
Adjustment of Diff-lock Wire.....	Page 5-14
Adjustment of Mower Stopper.....	Page 5-14
Adjustment of Wire to Hook Mower.....	Page 5-14
Long-Term Storage.....	Page 5-15
Before Long-Term Storage.....	Page 5-15

Maintenance

Maintenance Precautions

⚠ Caution

First, learn well the maintenance operations you plan to perform.

⚠ Caution

Use tools appropriate for each maintenance operation.

⚠ Caution

For the safe and best performance of your machine, use Baroness genuine parts for replacement and accessories.
Please note that our product warranty may be void if you use non-genuine parts for replacement or accessories.

Maintenance Schedule

Follow the maintenance schedule below.

○ . . . Inspect, adjust, supply, clean

● . . . Replace (first time)

△ . . . Replace

Maintenance Item		Before work	After work	Every 8 hrs.	Every 50 hrs.	Every 100 hrs.	Every 200 hrs.	Every 250 hrs.	Every 400 hrs.	Every 500 hrs.	Every year	Every 2 years	Every 4 years	Remarks
Engine	Tightening the parts	○												
	Fuel	○												
	Air cleaner	○					△							
	Engine oil	○		●	△									8 hrs (first time)
	Engine oil filter	○			●	△								50 hrs (first time)
	Ignition plug				○	△								
	Radiator	○												
	Oil cooler	○												
	Coolant	○			△									
	Fan belt	○									△			
	Battery	○										△		
	Battery fluid	○												
Cleaning the exterior	○													

Maintenance

Maintenance Item		Before work	After work	Every 8 hrs.	Every 50 hrs.	Every 100 hrs.	Every 200 hrs.	Every 250 hrs.	Every 400 hrs.	Every 500 hrs.	Every year	Every 2 years	Every 4 years	Remarks	
Main body	Tightening the parts	○													
	Interlock system	○													
	Emergency switch	○													
	Electrical wiring										○				
	Knife	○													
	Steering chain	○													
	Cutting (or brush) height	○													
	Greasing, oiling				○										
	Tire	○													
	Rubber crawler	○													
	V-belt	○									△				
	Brake	○													
	Wire	○					△								
	Cover	○													
	Oil leakage	○													
	Hydraulic oil	○				●					△				100 hrs (first time)
	Hydraulic oil filter					●					△				100 hrs (first time)
	Hydraulic motor oil				●		△								50 hrs (first time)
	Power unit oil	○				●					△				100 hrs (first time)
	Transmission oil	○			●						△				50 hrs (first time)
Hydraulic hose (moving part)	○											△			
Hydraulic hose (fixed part)	○												△		
Air cleaner	○						△								
Electromagnetic pump filter	○						△								
Fuel strainer					○					△					
Fuel pipe	○														
Cleaning the exterior	○														

The values for consumables are not guaranteed.
Replace the steering cylinder hoses every 2 years.

Maintenance

Specified Values

Fuel tank capacity	6.0 dm ³ (6.0 L)		
Quantity of transmission oil	2.0 dm ³ (2.0 L)	Transmission gear oil #90	
Quantity of engine oil	1.2 dm ³ (1.2 L)	Summer: SAE30, Winter: SAE20	
Front tire	200 kPa (2.0 kgf/cm ²)	4.00 - 5	
Rear tire	80 kPa (0.8 kgf/cm ²)	18 x 8.50 - 8	
Diff-lock wire	Create a slight play		
Brake pedal	5 - 7 mm	Clearance between pedal stopper and brake pedal	
Belt	Traveling clutch	5 mm	Clearance between rod-tension metal fitting and collar
	Reel rotation lever	5 mm	Clearance between rod-tension metal fitting and collar
	Left and Right Mower Units	1 mm	Clearance between collar and mower lifting arm
	Transmission	Approximately 10mm/98N (10kgf)	Belt slack
	Rear mower tension	1 mm	Clearance of spring
	Rear Mower Unit	Approximately 10mm/98N (10kgf)	Belt slack
Left / right mower stopper	90°	Angle against the frame	
Wire to hook the rear mower	The hook metal fitting should contact with the lever mounting bracket slightly.		
Wire to hook the left / right mower	Create a slight play	The hook metal fitting should contact with the bottom of the hook.	

Main Consumable Parts

Part Name	Code
Air cleaner element	K2740000030
V-belt OLB58	K2342058000
V-belt OLB66	K2342066000
V-belt GLB49A-4	K2344049000
V-belt OLB41	K2342041000
V-belt OLB31	K2342031000
V-belt GLA29A-4	K2324029000
Throttle wire	K1110135000
Reel rotation wire	K1160090000
Brake shoe	P2150-001304
Brake wire	K1120085010
Wire to hook the rear mower	K1170107000
Wire to hook the left / right mower	K1170051200

Jacking up the machine

About the Jacking up the machine

Warning

When replacing a tire or beginning any other maintenance or repairs, be sure to chock the wheels to prevent the machine from moving. Before jacking up the machine, park it on a hard, flat surface such as a concrete floor and remove any obstacles that could prevent you from performing the work safely. When necessary, use an appropriate chain block, hoist, or jack. Support the machine securely with jack stands or appropriate blocks. Failure to do so may cause the machine to move or fall, resulting in injury or death.

Use the jack-up points identified in this manual when jacking up the machine. Only place a jack under the jack-up points specified. Placing a jack at any other point could result in damage to the frame or other parts.

Jack-up Portion

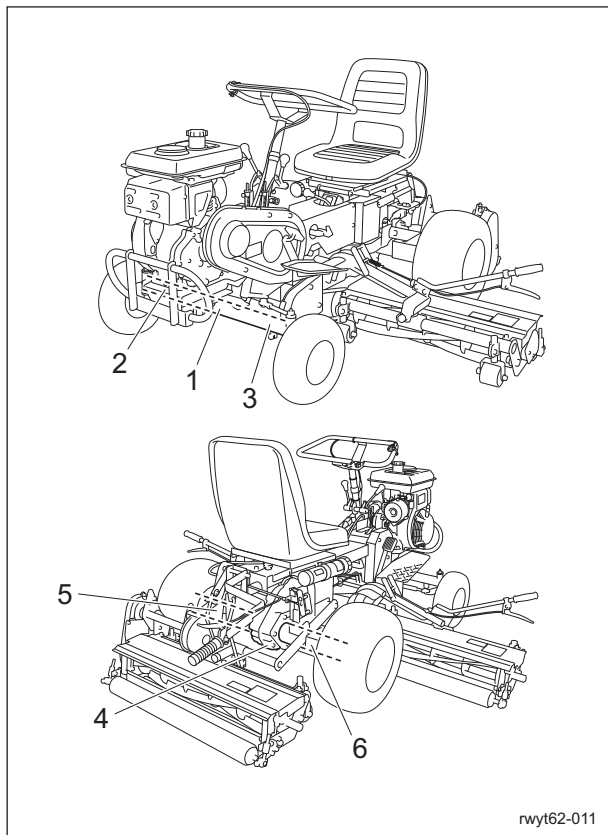

Jack-up Portion_001

	Jack-up Portion
1	Front axle, center
2	Front axle, right
3	Front axle, left
4	Transmission case, lower
5	Transmission axle case, left
6	Transmission axle case, right

1. Front axle, center

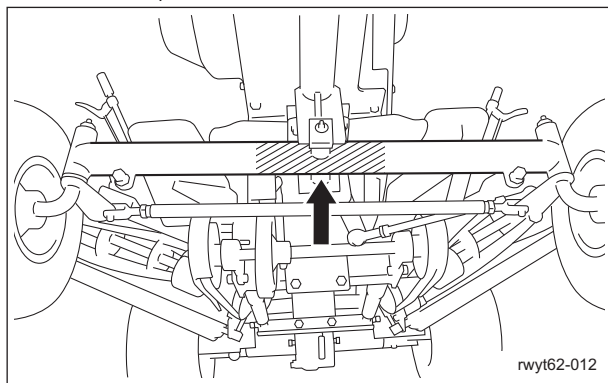

Jack-up Portion_002

2. Front axle, right

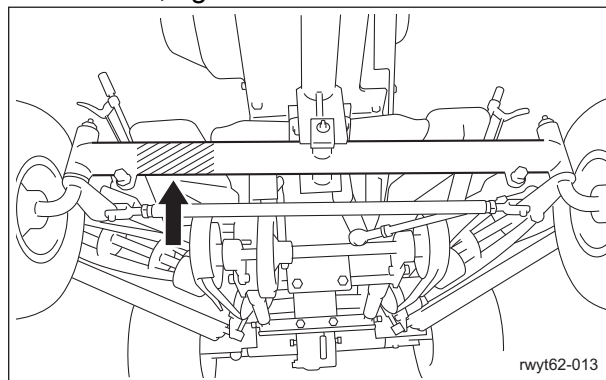

Jack-up Portion_003

3. Front axle, left

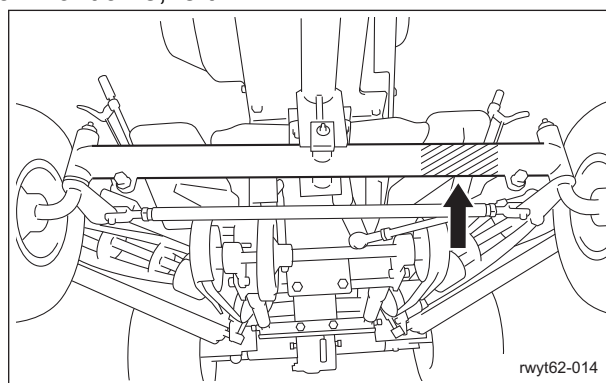

Jack-up Portion_004

4. Transmission case, lower

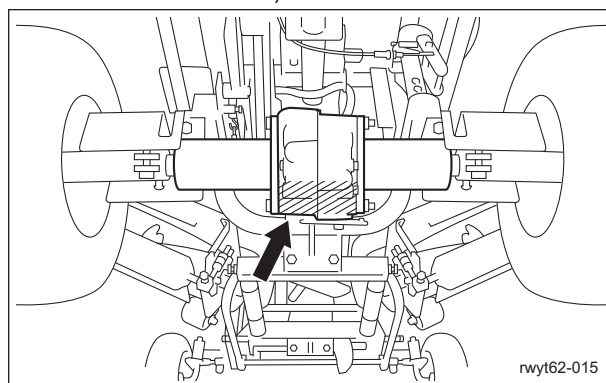

Jack-up Portion_005

5. Transmission axle case, left

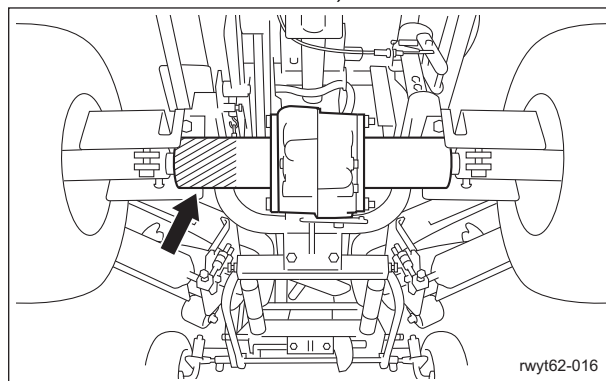

Jack-up Portion_006

Maintenance

6. Transmission axle case, right

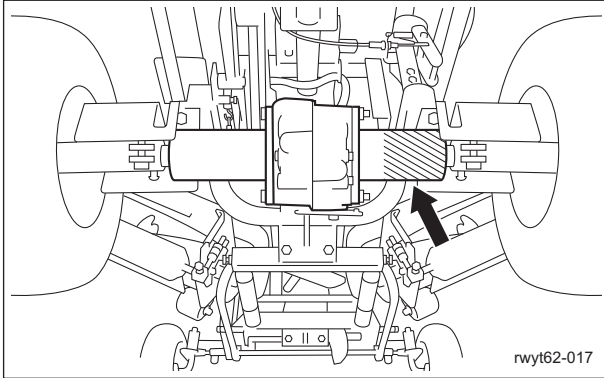

Jack-up Portion_007

Greasing

About the Lubrication

The moving parts of this machine need to be lubricated as a lack of grease on such parts could cause them to seize or be damaged. Grease the moving parts according to the maintenance schedule.

Greasing Points

Grease nipples are installed in the following locations.

Add grease every 50 hours of operation.

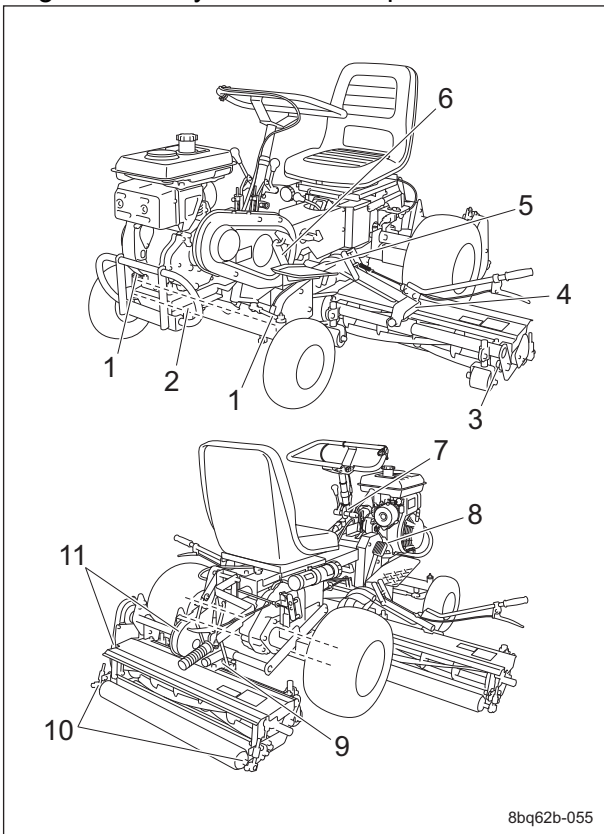

Greasing Point_001

	Portion	No. of Greasing Points
1	Front wheels	2
2	Front wheel front pin	1
3	Reel housing	6
4	Mower frame	2
5	Mower lifting arm	2
6	Diff-lock pedal	1
7	Handle tension	5
8	Brake pedal	1
9	Rear mower oscillating metal part	1
10	Rear roller	6
11	Mower tension	2

1. Front wheels

There is one point each on the left and the right wheel.

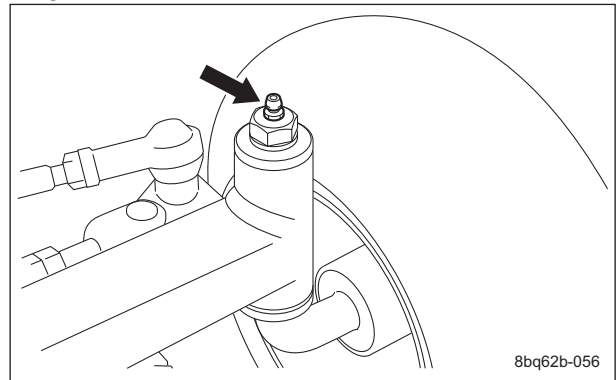

Greasing Point_002

2. Front wheel front pin

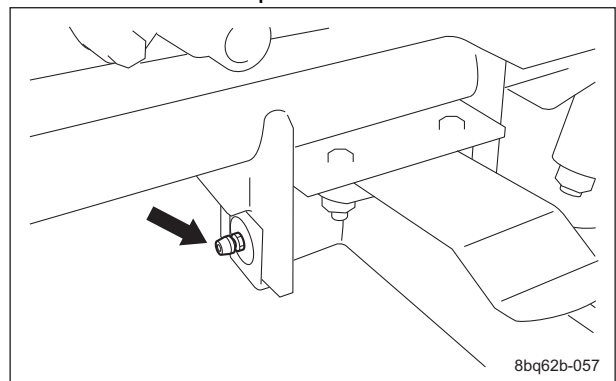

Greasing Point_003

3. Reel housing

There is one point each on the left and the right of each unit.

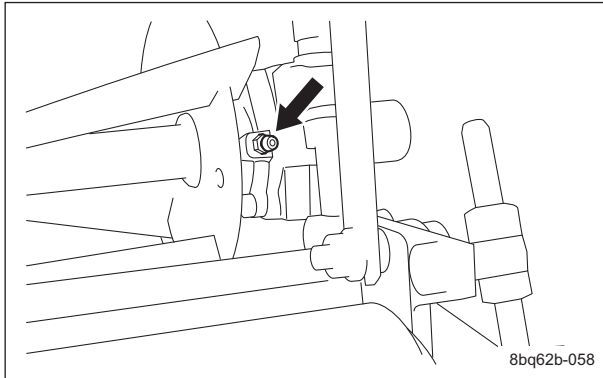

Greasing Point_004

4. Mower frame

There is one point each on the left and the right mower units.

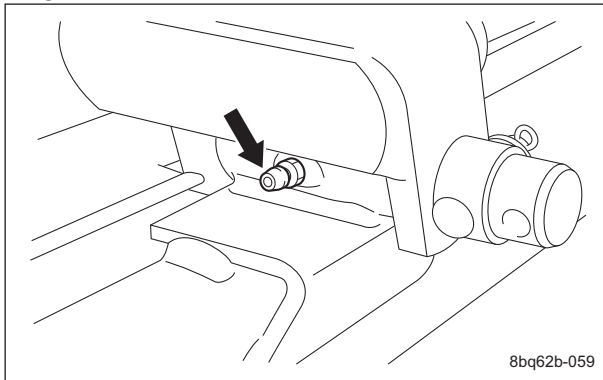

Greasing Point_005

5. Mower lifting arm

There is one point each on the left and the right mower units.

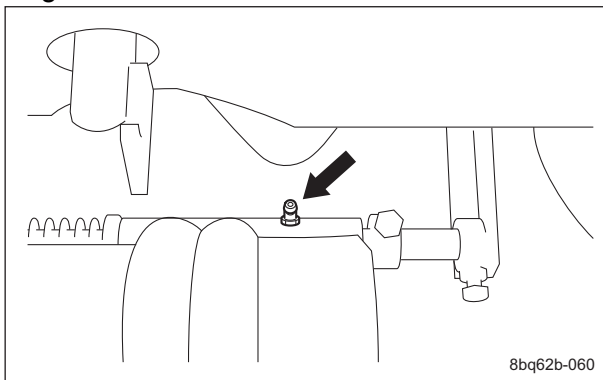

Greasing Point_006

6. Diff-lock pedal

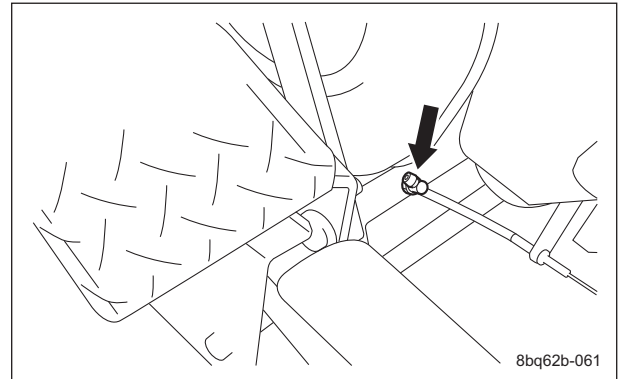

Greasing Point_007

7. Handle tension

Supply automobile transmission gear oil #90 every 50 hours of operation.

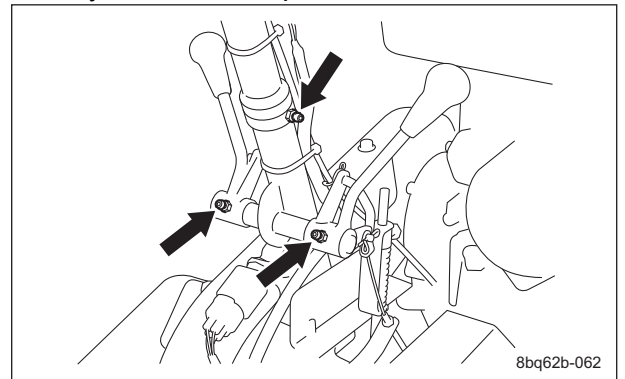

Greasing Point_008

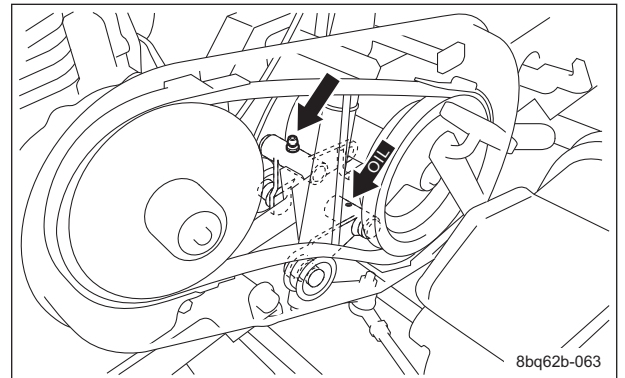

Greasing Point_009

8. Brake pedal

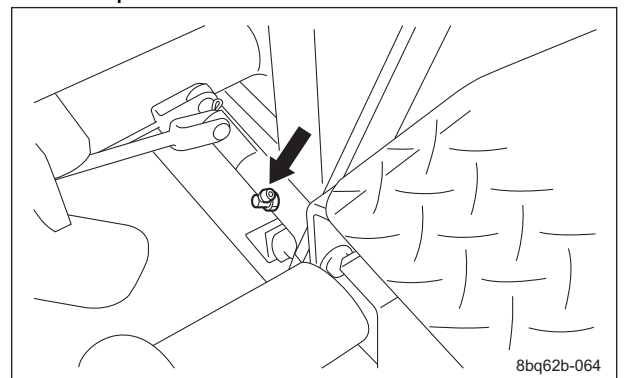

Greasing Point_010

Maintenance

9. Rear mower oscillating metal part

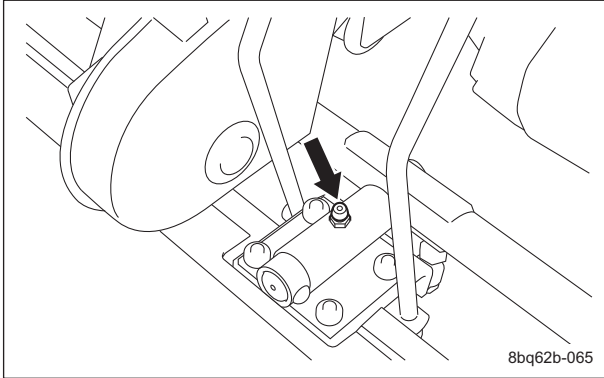

Greasing Point_011

10. Rear roller

There is one point each on the left and the right of each unit.

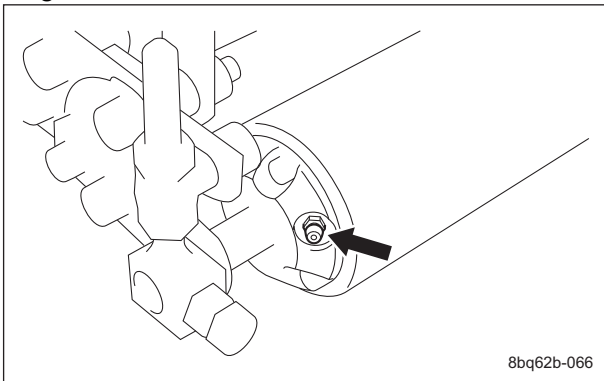

Greasing Point_012

11. Mower tension

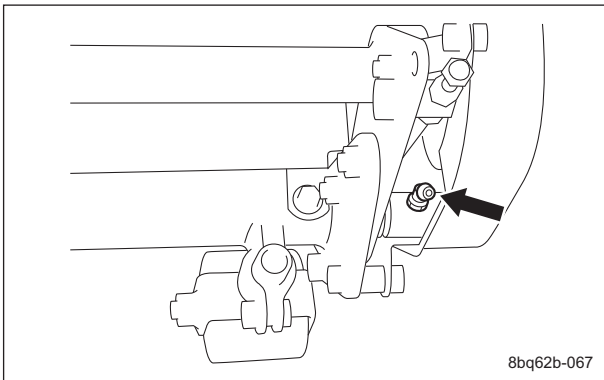

Greasing Point_013

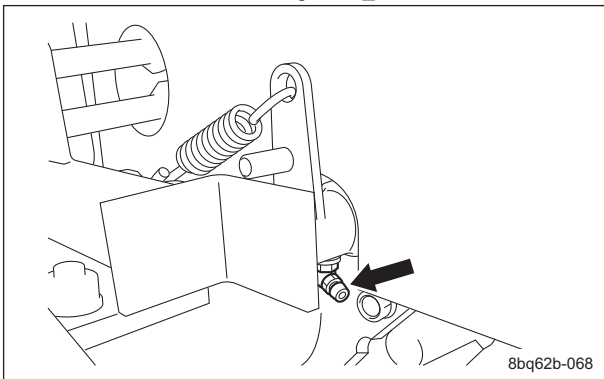

Greasing Point_014

Maintenance (Mower)

Lapping of Reel Cutter (Cutting Cylinder)

Lapping is work similar to sharpening a cooking knife. If the edges of the reel cutter (cutting cylinder) and the bed knife (bottom blade) become blunt and make cutting difficult, both the reel cutter (cutting cylinder) and the bed knife (bottom blade) should be simultaneously sharpened by reversing the reel cutter (cutting cylinder) with an abrasive paste applied. However, lapping is a temporary measure and would not restore the sharpness completely. If the edges of the reel cutter (cutting cylinder) and the bed knife (bottom blade) become blunt and difficult to cut, follow the steps below to perform lapping.

⚠ Caution

Both the reel cutter (cutting cylinder) and the bed knife (bottom blade) are edged tools. Handle them carefully, since they could cut your hands and feet.

⚠ Caution

During lapping, the reel cutter (cutting cylinder) rotates. Keep hands and feet away from moving parts.

⚠ Caution

Do not perform lapping with any other persons.

1. Have the following items ready: Lapping machine [Baroness RM20B], Strips of newspaper, Abrasive [Lapping powder mixed with oil; or gel compound (Baroness genuine abrasive)], Brush, 27 socket wrench.

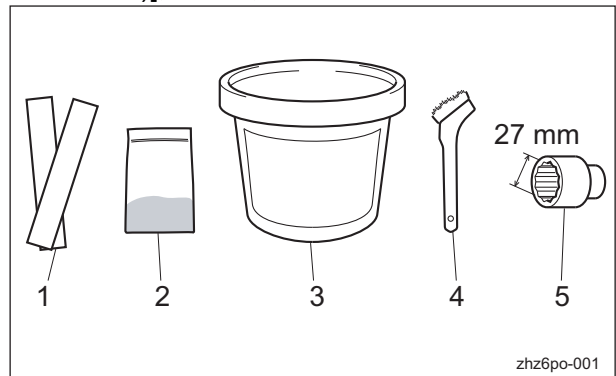

Lapping of Reel Cutter (Cutting Cylinder)_001

1	Newspaper
2	Lapping powder
3	Gel compound
4	Brush
5	27 socket wrench

Note:

Mixing ratio for abrasive in volume is one part lapping powder to three or four parts oil.

Caution

Before cutting newspaper as a test, be sure to stop the engine and wear gloves to protect your hands.

Pay attention not to let the reel cutter (cutting cylinder) catch your gloves. Otherwise, you may injure your hand or fingers.

Important

After cutting grass, adjust the engagement of the blades, before checking the sharpness of the blade.

2. Insert two or three strips of newspaper into the space between the reel cutter (cutting cylinder) and the bed knife (bottom blade) at an angle of 90 degrees, then rotate the reel cutter (cutting cylinder) from up to down manually to check the sharpness.
3. Check the sharpness at entire range (three or four points from left edge to right one) of the reel cutter (cutting cylinder).
4. Using a piece of chalk, mark locations on the blade that are sharp.
5. Lower the mower unit, then using the 27 socket wrench, connect the lapping machine and the shaft of reel cutter (cutting cylinder).
6. Turn on the switch of the lapping machine to rotate the reel cutter (cutting cylinder) in the direction opposite to the cutting direction.
7. Apply the abrasive evenly with the brush on the top side of reel cutter (cutting cylinder) where the newspaper was cut well or of chalk-marked locations.
8. Idle the machine for a while, and then switch off the lapping machine to stop rotation when contact noise is no longer heard.
9. Wash off or wipe off with cloth etc. the abrasive from the reel cutter (cutting cylinder), then check it for sharpness.

10. Repeat steps 2 to 9 until the entire range (three or four points from left edge to right one) of the reel cutter (cutting cylinder) will be uniformly sharpened.
11. Finally, apply the abrasive on the entire range of the reel cutter (cutting cylinder) and perform final lapping.
12. Stop the rotation of the reel cutter (cutting cylinder), and then wash off the abrasive using a washer.
13. While checking the blade for sharpness, adjust blade engagement.

Maintenance (Main Body)**Removing/Installing Tires****Front Tires**

Follow the steps below to remove the front tires:

1. Loosen the bolts.

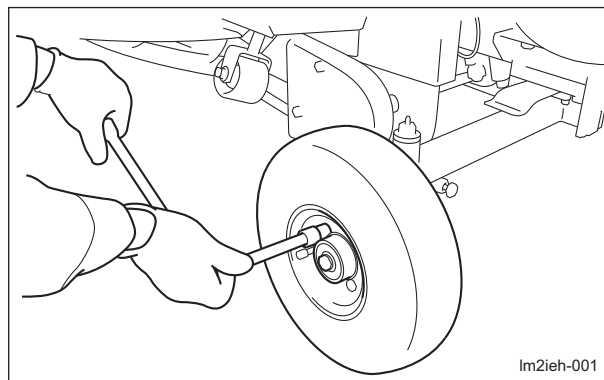

Front Tires_001

2. Place the tire jack beneath the jack-up point of the front axle area securely, then raise it until the tire lifts off the ground. (See .)
3. Remove the bolts.
4. Remove the tire from the wheel mounting shaft.

Caution

Refer to the Tightening Torque table. Note that the Baroness product warranty may not apply to defects caused by incorrect or overtorque tightening.

Important

Tighten the bolts in the tightening order (crosswise).

For installing the front tires, reverse the removing procedure.

Maintenance

Rear Tires

Follow the steps below to remove the rear tires:

1. Loosen the bolts.

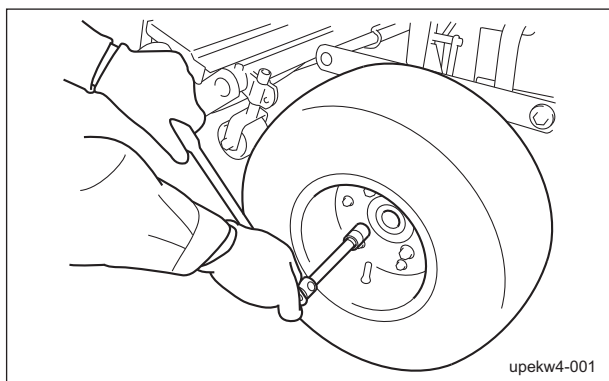

Rear Tires_001

2. Place the tire jack beneath the jack-up point of the rear wheel transmission area securely, then raise it until the tire lifts off the ground. (See .)
3. Remove the bolts.
4. Remove the tire from the wheel mounting shaft.

⚠ Caution

Refer to the Tightening Torque table. Note that the Baroness product warranty may not apply to defects caused by incorrect or overtightening.

Important

Tighten the bolts in the tightening order (crosswise).

For installing the rear tires, reverse the removing procedure.

Adjustment of Belt Tension

⚠ Caution

Be sure to stop the engine before adjusting the belts.

Important

Make sure that the belt has the specified amount of tension.

If the belt becomes slack due to frequent use, it may jump or slip.

In addition, if it is overtightened, it may wear prematurely.

If necessary, adjust it, and always check the belt for appropriate tension.

Belt Installation Locations

V-belts are installed in this machine at the following locations.

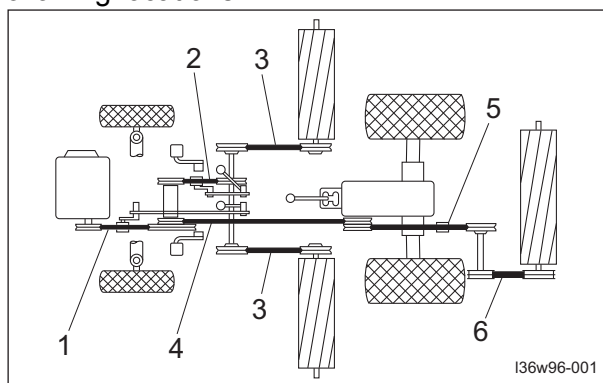

Belt Installation Locations_001

1	Traveling clutch
2	Reel rotation lever
3	Left and Right Mower Units
4	Transmission
5	Rear mower tension
6	Rear Mower Unit

Traveling clutch

1. Loosen the adjustment bolt, then change the length of the rod.
2. Adjust the clearance between the rod-tension metal fitting and the collar to be 5mm, when the traveling clutch lever is engaged.
3. Tighten the adjustment bolt and make sure that the collar is fixed securely.

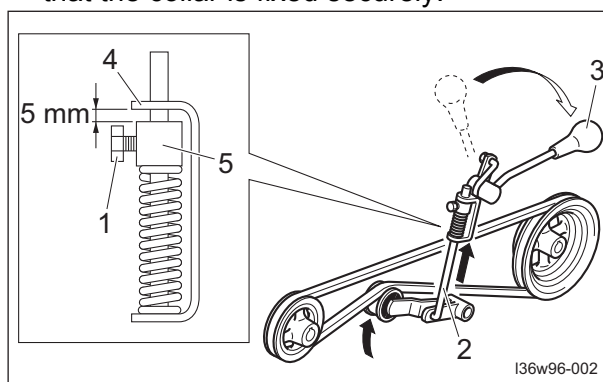

Traveling Clutch_001

1	Adjustment bolt
2	Rod
3	Traveling clutch lever
4	Rod-tension metal fitting
5	Collar

Reel rotation lever

1. Loosen the adjustment bolt, then change the length of the rod.
2. Adjust the clearance between the rod-tension metal fitting and the collar to be 5mm, when the traveling clutch lever is engaged.
3. Tighten the adjustment bolt and make sure that the collar is fixed securely.

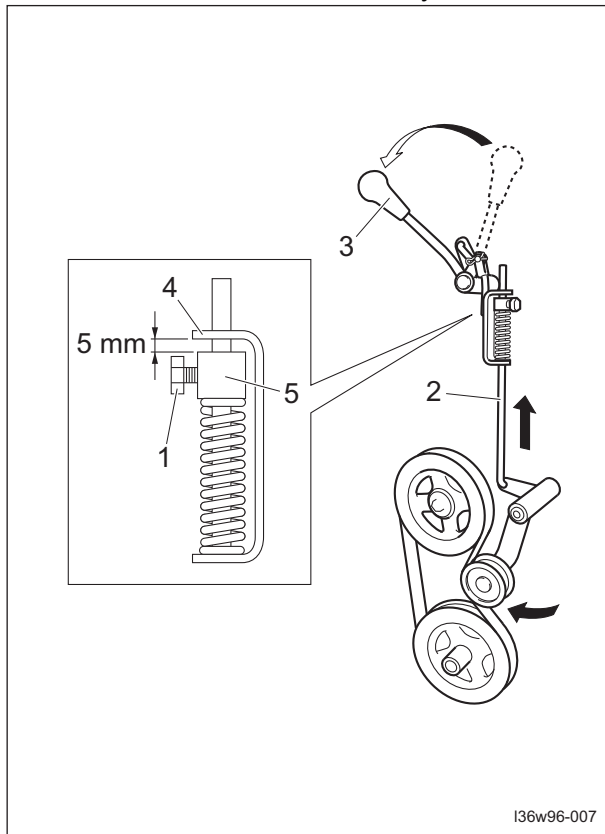

Reel Rotation Lever_001

1	Adjustment bolt
2	Rod
3	Traveling clutch lever
4	Rod-tension metal fitting
5	Collar

Left and Right Mower Units

1. V-belts are always stretched at a constant tension by the springs. Loosen the adjustment bolt, then adjust the clearance between the collar and the mower lifting arm to be 1mm.
2. Tighten the adjustment bolt and make sure that the collar is fixed securely.
3. Follow the same steps to adjust the belts on the mower unit on the opposite side.

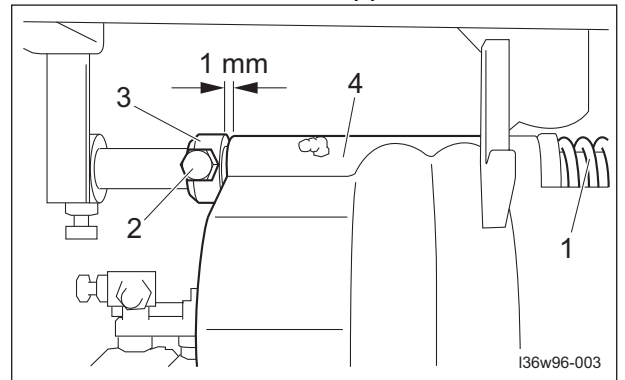

Left and Right Mower Units_001

1	Spring
2	Adjustment bolt
3	Collar
4	Mower lifting arm

Transmission

1. Loosen adjusting nut A.
2. Tighten adjusting nut B, then change the length of the rod.
3. Adjust the V-belt tension so that the belt slacks by approximately 10mm when you press the middle of the belt with your finger at 98N (10kgf).
4. Tighten adjusting nut A and make sure that the rod is fixed securely.

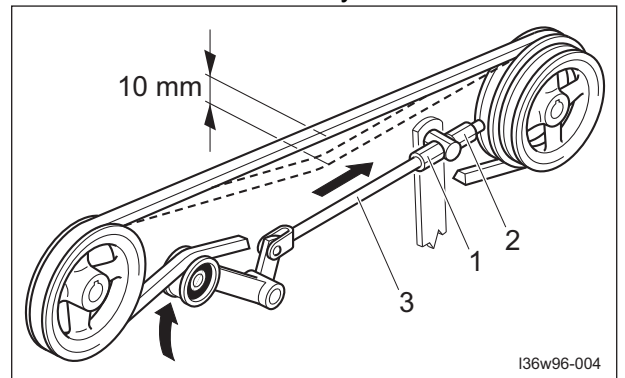

Transmission_001

Maintenance

1	Adjusting nut A
2	Adjusting nut B
3	Rod

Rear mower tension

1. Loosen adjusting nut A.
2. Tighten adjusting nut B, then change the length of the rod.
3. Lower the rear mower unit on a level surface, then adjust the clearance of the spring to 1mm.
4. Tighten adjusting nut A and make sure that the rod is fixed securely.
5. Raise the rear mower unit, then make sure that the reel cutter (cutting cylinder) will not rotate when the machine travels.

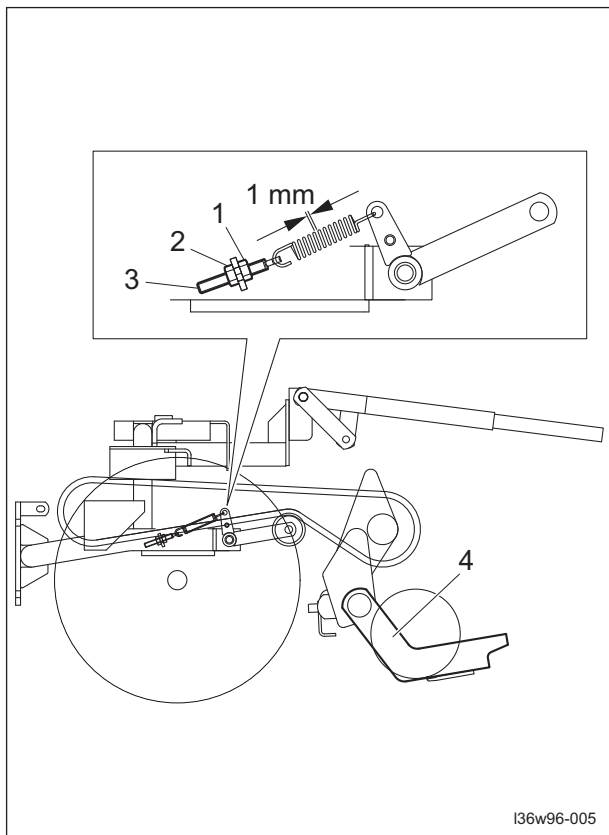

Rear Mower Tension_001

1	Adjusting nut A
2	Adjusting nut B
3	Rod
4	Rear mower unit

Rear Mower Unit

1. Loosen adjusting nut A.
2. Tighten adjusting nut B, then change the length of the rod.

3. Adjust the V-belt tension so that the belt slacks by approximately 10mm when you press the middle of the belt with your finger at 98N (10kgf).
4. Tighten adjusting nut A and make sure that the rod is fixed securely.

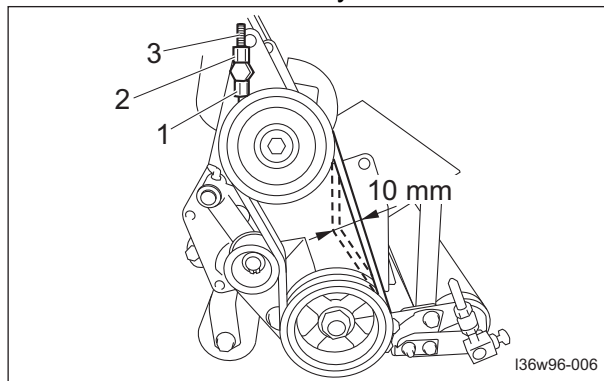

Rear Mower Unit_001

1	Adjusting nut A
2	Adjusting nut B
3	Rod

Adjustment of Parking Brake

If the parking brake is not effective enough when you pull the parking brake lever, adjust the brake wire.

1. While pressing the push button, return the parking brake lever to its resting position to release the parking brake.
2. Loosen the nut on the parking brake lever side.
3. Move the wire adjustment bracket toward the rear to increase the wire tension.
4. Tighten the nut securely to fix the wire adjustment metal fitting.

5. Make sure that the brake is applied properly when you pull the parking brake lever, and that there is no brake dragging when you release the parking brake lever.

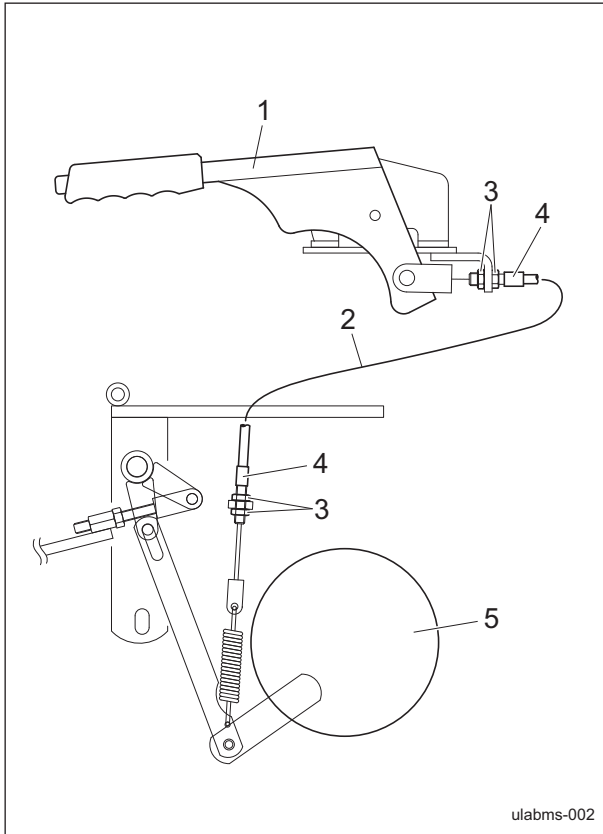

Adjustment of Parking Brake_001

1	Parking brake lever
2	Brake wire
3	Nut
4	Wire adjustment metal fitting
5	Brake drum

Note:

You can also adjust the brake wire on the transmission side.

Adjustment of Brake

If the brake is not applied effectively even if you depress the pedal up to the stopper, adjust the brake rod.

1. Pull the parking brake lever completely and make sure that the brake is effectively applied.
2. Loosen the lock nut.
3. Remove the cotter pin, washer and pin that affix the brake pedal to the front of the brake rod.

4. Screw in the nut on the front of the brake rod, then temporarily affix the brake pedal to the front of the brake rod using the pin.
5. Depress the brake pedal lightly, and adjust the clearance between the pedal stopper and brake pedal to 5-7mm. (If the clearance is larger than 7mm, the brake may be damaged.)
6. Affix the brake pedal to the front of the brake rod securely using the pin.
7. Tighten the lock nut to secure the front of the brake rod firmly.
8. Make sure that the brake is not applied any longer when you release the brake pedal.

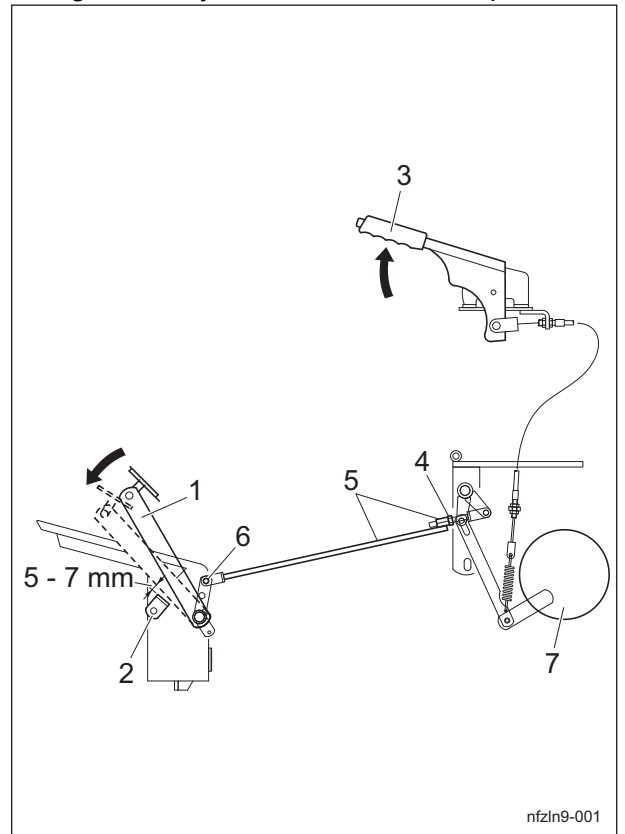

Adjustment of Brake_001

1	Brake pedal
2	Pedal stopper
3	Parking brake lever
4	Lock nut
5	Brake rod (front)
6	Cotter pin, washer, pin
7	Brake drum

Maintenance

Adjustment of Diff-lock Wire

If the diff-lock seems ineffective when you depress the diff-lock pedal, adjust the diff-lock wire.

1. Make sure that the diff-lock pedal has completely returned to its resting position.
2. Loosen the nut on the transmission side.
3. Loosen the wire adjustment bracket upward to increase the wire tension.
4. Adjust the wire so that the diff-lock wire and the diff-lock lever show a little play when the lever returns to its resting position under spring tension.
5. Tighten the nut and fix the wire adjustment bracket completely.

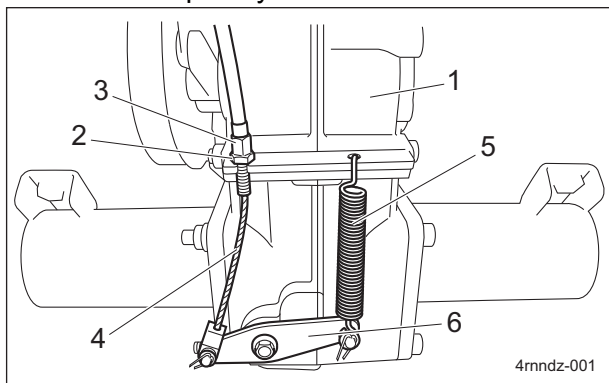

Adjustment of Diff-lock Wire_001

1	Transmission
2	Nut
3	Wire adjustment bracket
4	Wire
5	Spring
6	Diff-lock lever

Note:

You can also adjust the diff-lock wire on the pedal side.

Adjustment of Mower Stopper

1. Lower the left and right mower units, then engage the reel rotation lever.
2. Loosen the nut, then adjust the position of the wire adjustment bracket so that the mower stopper will be positioned at 90 degrees against the frame.
3. Tighten the nut securely to fix the wire adjustment bracket.

4. Make sure that the mower stopper will spring back when you release the reel rotation lever.

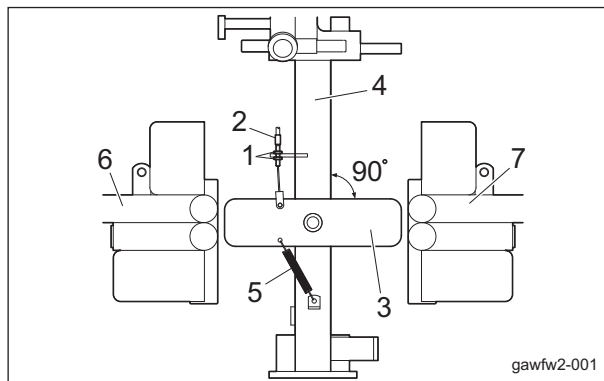

Adjustment of Mower Stopper_001

1	Nut
2	Wire adjustment bracket
3	Mower stopper
4	Frame
5	Spring
6	Left mower lifting arm
7	Right mower lifting arm

Adjustment of Wire to Hook Mower

Wire to hook the left / right mower

1. Loosen the nuts and move the wire adjustment metal fitting toward the outside of the machine to increase the wire tension.
2. Without gripping the lever, raise the right mower unit, then make adjustment so that the hook metal fitting will be in touch with the bottom of the hook and the wire will have a small play.
3. Tighten the nuts and fix the wire adjustment metal fitting securely.
4. Follow the same steps to adjust the hook wire of left mower.

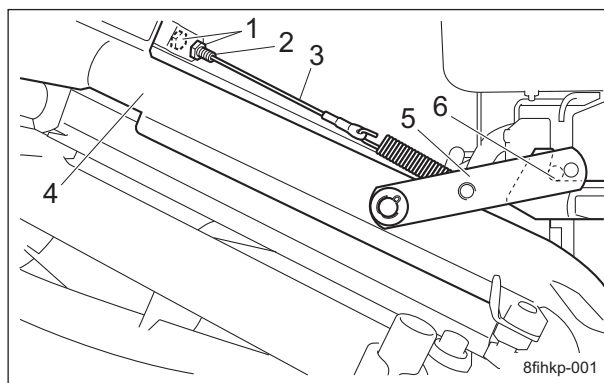

Wire to hook the left / right mower_001

1	Nut
2	Wire adjustment bracket
3	Wire (to hook the mower)
4	Right mower unit
5	Hook metal fitting
6	Bottom of the hook

Wire to hook the rear mower

1. Loosen the nuts and move the wire adjustment metal fitting toward the center of the machine to increase the wire tension.
2. Lower the rear mower unit, then adjust the hook metal fitting to come into contact slightly with the lever mounting bracket when you grip the lever completely.
3. Tighten the nuts and fix the wire adjustment metal fitting securely.

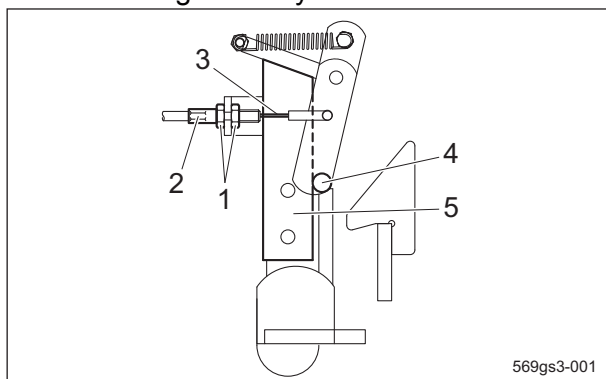

Wire to hook the rear mower_001

1	Nut
2	Wire adjustment metal fitting
3	Wire
4	Hook metal fitting
5	Lever mounting bracket

4. When the hook metal fitting returns to its original position by spring tension as soon as you release the lever, raise the rear mower lifting arm and make sure that the hook metal fitting is located closer to the center of the machine than the upper tip of the hook.

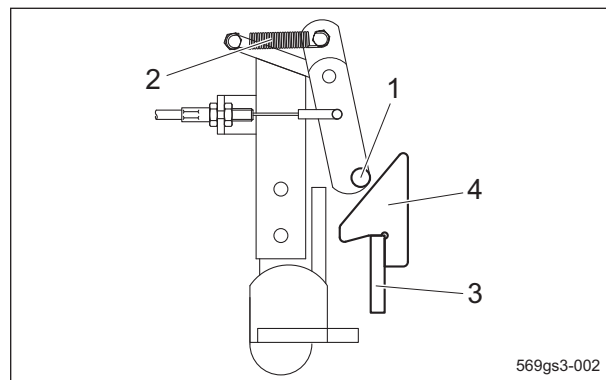

Wire to hook the rear mower_002

1	Hook metal fitting
2	Spring
3	Rear mower lifting arm
4	Hook

Long-Term Storage

Before Long-Term Storage

- Remove any dirt, grass, debris, or oil stains completely.
- Supply oil and apply grease to appropriate parts.

BARONESS[®]
Quality on Demand



BEVATTNINGSTEKNIK AB
Helsingborgsvägen 578, Varalöv
262 96 ÄNGELHOLM, SWEDEN

Telefon: +46 431 22250
Email : info@bevattningsteknik.se eller philip@bevattningsteknik.se
www.bevattningsteknik.se